

Super Purified Glovebox Gas Purification System



ABOUT US

Achieving Social Goals through Advancing Technology



Vacuum Technology is a US based manufacturer that is committed to developing innovative products for clients around the world.

With its North American facility in Gloucester, Massachusetts USA, VTI offers Super Purified Gloveboxes, Gas Purification Systems and ancillary products and accessories. In addition to the standard product lines, we are proud of our technical team's ability to work together with our clients to create custom solutions.

VTI's high-quality products and dedicated service have been developed to earn the confidence of our clients and the respect of our colleagues world-wide.

Through collaboration with various international market-leading manufacturers and comprehensive technology sharing with Mikrouna (over 20 years of Glovebox innovations and engineering), VTI has become an industry leader in integrating research, manufacturing, sales, and customer service.

Vacuum Technology continues to develop innovative high-quality products while providing exemplary service to fulfill our goal of "Achieving Social Goals through Advancing Technology".

PRODUCT FEATURES

- **High Capacity Purifier**

Rapid removal of H₂O and O₂ to less than 1ppm.

Long intervals between regeneration cycles.

- **PLC Control and Color Touchscreen HMI**

Automatic PLC Controlled Purge, Circulation, Regeneration and Pressure control.

User Friendly Interface.

- **Manifold Style Solenoid Valve Seat**

Manifold structure; stainless steel.

Fewer connections and lower leakage risk.

- **Components Sourced from Global Best in Class Suppliers**

- **INTERNET REMOTE CONTROL-NEWLY INTRODUCED**

- **Long Life Moisture and Oxygen Analyzers**

P₂O₅ Moisture Sensor: Corrosion resistant, Renewable by acid-cleaning if the probe is contaminated with HF or other corrosive environmental exposure.

ZrO₂ Oxygen Sensor: Solid state sensor, long life, can be exposed to air without consumption.

- **Customize a Glovebox Specially for your Application**

Our engineering team can help to turn your idea into a solution.

- **Wide Applications**

Lithium Battery / Physical Chemistry / OLED&PLED / Organometallic / Solar Cell / Semi-Conductor / Catalyst / Material Handling / Fine Chemicals / Polymeric Materials / Powder Metallurgy / Special Welding / Special Lamps / Nuclear Technology / Pharmaceutical / Many other applications.



Remote Monitoring and Control of Glovebox from Computer or Smartphone

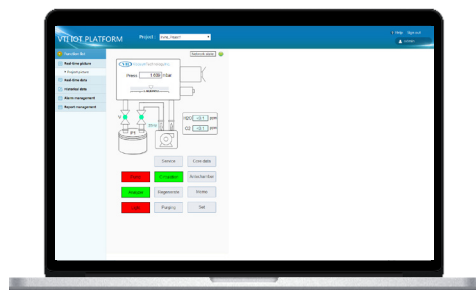

Failure Alarm



Remote Troubleshooting



Data Encryption and Backup

GLOVEBOX GALLERY



Super(1220/750/900)



Universal(1500/750/900)



Universal(1800/750/900)



Universal(2440/750/900)



Advanced(2440/1000/900)



Glovebox with Independent Purification System



Glovebox with Refrigerator



Glovebox with Microscope Unit

GLOVEBOX GALLERY



T-Antechamber Glovebox



Glovebox with Air Conditioner



Glovebox with Vacuum Oven

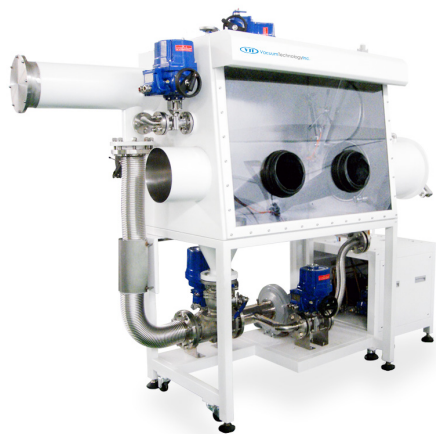

For the Electrolyte Field



Vacuum Glovebox



Quick Released Window – Hinged

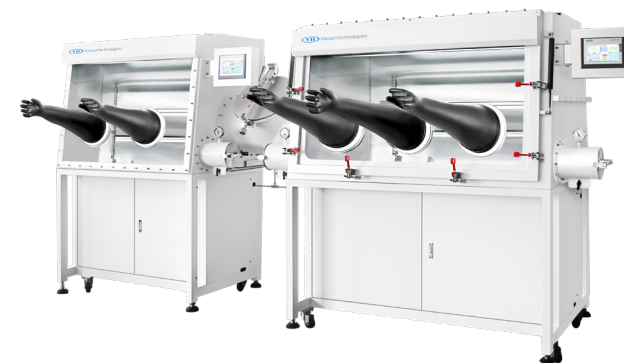

Quick Released Window – Clamped



Super Capacitor Production Line



For 3D Printing



For OLED / Solar Cell



For OLED



For Rare Earth Metal Welding



For Lithium Ion Battery



For Melt Casting



For Welding



For Nuclear Power



For Nuclear Material

LITHIUM BATTERY / SUPER CAPACITOR RESEARCH AND PRODUCTION

Lithium Battery Research Glovebox

- Regenerable Solvent Trap
- HF (Hydrofluoric Acid) Absorber
- Heated Antechamber
- Acid Proof Moisture Sensor



Blower

Purifier

Regenerable
Solvent Trap

HF Absorber

Super Capacitor / Lithium Battery Production Line

- Movable oven, PLC Controlled to 200°C.
- Exclusive docking system between oven and antechamber prevents capacitor exposure to ambient air.
- Fully automated transfer between oven, cooling antechamber, glovebox, and discharge chambers.
- Cooled Antechamber helps to reduce energy consumption and enhance efficiency.
- One Glovebox system quipped with multiple ovens sequentially helps to save cost.
- Best for small batches of various samples.





“All-In-One” Super Capacitor/Lithium Battery System

- Large capacity PLC controlled oven integrated with glovebox.
- Fully Automated Transfer System:
 - Smoothly transfers items between oven, glovebox and discharge chamber.
 - Automatically moves items between INJECTING, SEALING and STANDBY processes.
- High volume throughput.
- Best for large batches of similar products.



OLED / SOLAR CELL / PEROVSKITE CELL



- Applicable for metal, semi-conductor, and organic film, OLED, PLED, Solar, Perovskite Cell and other applications.
- Integrated with Evaporator and Spin Coater.
- With Ultra-clean Purification System on the top.
 - Cleanliness level reached to 10.
 - High efficiency filter H13 grade to ultra-high efficiency filter U15 grade.
 - Filtration particle size: 0.12 μ m.



3D PRINTING SERIES

3D printing glovebox (rapid prototyping glovebox) is designed for manufacturing special components and parts used in aerospace engineering. 3D printing by Powder Feeding Molding and Laying Powder Molding are common configurations in a glovebox. Each molding technique uses a specially designed glovebox based on the requirements.

Features

- Large volume sealing, with high reliability.
- Signal wires and Power wires are highly integrated into the sealing box, avoiding interruptions.
- Automated robotic loading & unloading and transmission.
- Professionally designed antechamber whose surface is sprayed with plastic or mirror surface, the structure is ingenious and the opening is convenient and simple.



WELDING SERIES

- Avoid the effect of humidity and impurities in the air while laser welding.
- The glovebox has two rectangular Antechambers, one Heated Antechamber (Maximum 200°C and quick chilling) with water cooling unit and one regular antechamber.
- The outside door of the rectangular antechamber is manually operated and the inside door is automatically operated.
- The glovebox purge is controlled by the flow meter; the glovebox can also be connected with a purification system.
- The system has a dust removal unit.



SPECIFICATIONS

Glovebox

Main Chamber

Material:	Stainless Steel Type 304, Thickness 3mm (1/8")
External Surface:	White Paint (Brushed Stainless Steel Available)
Internal Surface:	Brushed Stainless Steel
Inside Dimension:	Modular length: 1220mm/1500mm/1800mm/2440mm 48.0"/59.1"/70.9"/96.0"
	Modular Depth: 750mm/1000mm/1200mm 29.5"/39.4"/47.2"
	Modular Height: 900mm 35.4"

Sight Windows Inclined, Safety Glass, Thickness 8mm (1/3")(Polycarbonate available)

Gloves Ports POM (Polyoxymethylene), double O-ring seal, 220mm (8.7") Diameter

Gloves Butyl, 8" cuff dia., 0.015"thick, 32" long (many other materials and sizes available specific to your needs)

Dust Filter HEPA 0.3µm, one on gas inlet, one on gas outlet

Shelving Stainless Steel material, two fixed shelves (adjustable shelves available)

Box Light LED, front and top mounted

Feedthroughs KF40, One Power cord feedthrough, backup ports for various feedthroughs (BNC, USB, Post Connector, VGA, Liquid / Gas feedthroughs and custom feedthroughs available on request)

- CLOSED LOOP GAS CIRCULATION
- AUTOMATIC PURGING
- AUTOMATIC REGENERATION



SPECIFICATIONS

- PRESSURE CONTROL IN THE GLOVEBOX
- AUTOMATIC VACUUM PUMP CONTROL
- ECO MODE

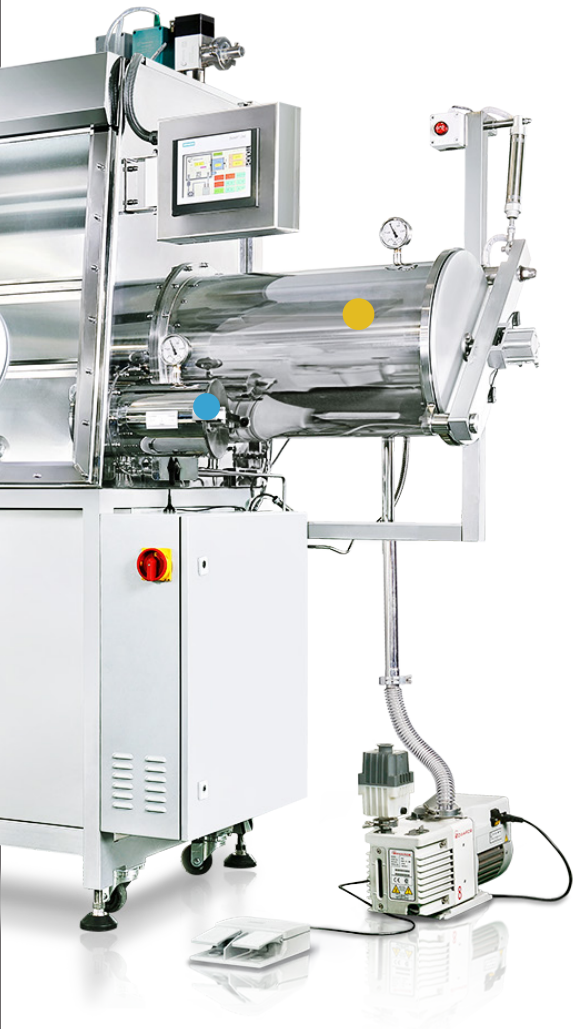

● Main Antechamber

Size:	Diameter: 360mm (14.2") or 400mm (15.7"), Length 600mm (23.6") (other sizes available)
Materials:	304 Stainless Steel
External Surface:	White Paint (Polished Stainless Steel available)
Internal Surface:	Brushed Stainless Steel
Sliding Tray:	304 Stainless Steel
Double Door:	Anodized Aluminum, 10mm thick (2/5"); Vertical operation with lifting mechanism (Interlocking door available)
Manometer:	Analog Display
Operation:	Touch Screen Automatic operation via solenoid valves

● Mini Antechamber

Size:	Diameter: 150mm (5.9") or 100mm (3.9"), Length 300mm (11.8")
Materials:	304 Stainless Steel
External Surface:	White Paint (Polished Stainless Steel available)
Internal Surface:	Brushed Stainless Steel
Double Door:	Hinged (Interlocked double door available)
Manometer:	Analog Display
Operation:	Manual operation via hand valve

SPECIFICATIONS

Gas Purification Unit

Purifier

Function:	Airtight Seal, Removal of H ₂ O and O ₂
Container Material:	304 Stainless Steel
Absorber Material:	5kg Copper Catalyst 5kg Molecular Sieve
Attainable Purity:	Less than 1 ppm moisture and oxygen

Gas Circulation

Working Gas:	Nitrogen, Argon or Helium
Encapsulated Blower:	90m ³ /h (145m ³ /h or 180m ³ /h available)

Regeneration

Operation:	PLC automatically controlled
Regeneration Gas:	Working gas mixed with Hydrogen (5-10%)



Purification system

SPECIFICATIONS

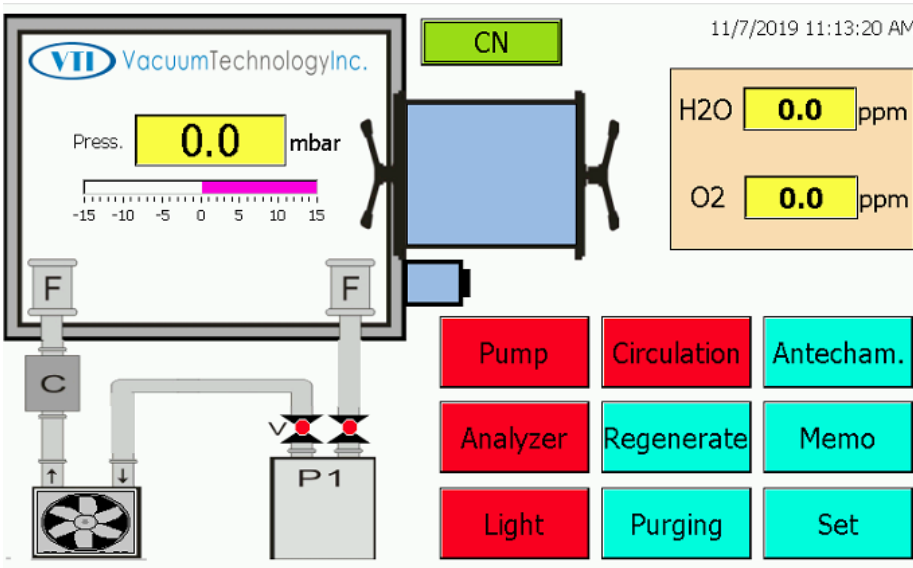

System Control

- PLC and HMI: Siemens S7
- Touch Screen: Siemens 7", color
- Features: Automatic control of Purging, Circulation Control, Regeneration, Pressure, as well as Self-Diagnosis, Power Failure Re-Start and Password Protection.
- Box Pressure set: Between +/-12mbar, automatic protection when system is over +/-15mbar.

Vacuum Pump

12 m³/h or 17 m³/h
 Rotary vane pump with oil mist and gas ballast control unit
 (Dry pump is available)

Valves

- Main Valves: Electro-pneumatic angle valves KF 40
- Control Valves: Integrated Solenoid Valves

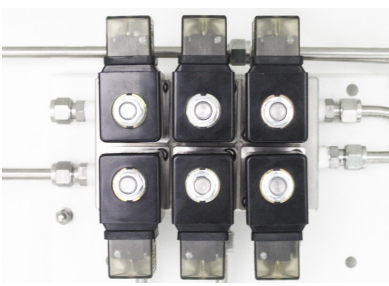

Manifold Style Solenoid Valve Seat

MODEL AND SIZE

Standard Glovebox

Items		Model	Super/Upure	Universal	Advanced
Workstation	Single		1220/750/900	1220/750/900	1220/750/900
	Double(side by side) Double(face to face)			2440/750/900 1800/750/900 1220/1000/900	2440/750/900 1800/750/900 1220/1000/900
	Tri-glove(side by side)			1500/750/900 1800/750/900	1500/750/900 1800/750/900
	Four(side by side) Four(face to face)			4800/750/900 2400/1000/900	4800/750/900 2400/1000/900
	Six(face to face) Eight(face to face)			3600/1000/900 3660/1200/900 4800/1000/900 4800/1200/900	3600/1000/900 3600/1200/900 4800/1000/900 4800/1200/900
	Twelve(face to face)			7320/1000/900	7320/1000/900
	Control unit		Siemens S7	Siemens S7	Siemens S7
	Touch screen		7" Screen	7" Screen	7" Screen
	Purifier		Single	Single	Double
	Blower		90m ³ /h	90/145/180m ³ /h	90/145/180m ³ /h
	Vacuum pump		12m ³ /h	12/17m ³ /h	12/17m ³ /h
	Moisture		<1ppm	<1ppm	<1ppm
	Oxygen		<1ppm	<1ppm	<1ppm
	Application		R&D type For R&D in University and Laboratory	Universal type For both R&D and small-scale production	Production type For large-scale production

Upure: With internet remote control and automatic antechamber door.

DIMENSIONS

Standard Glovebox

Depth and Height

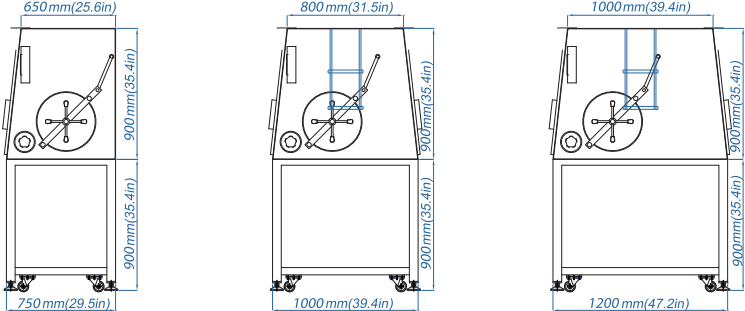

Length

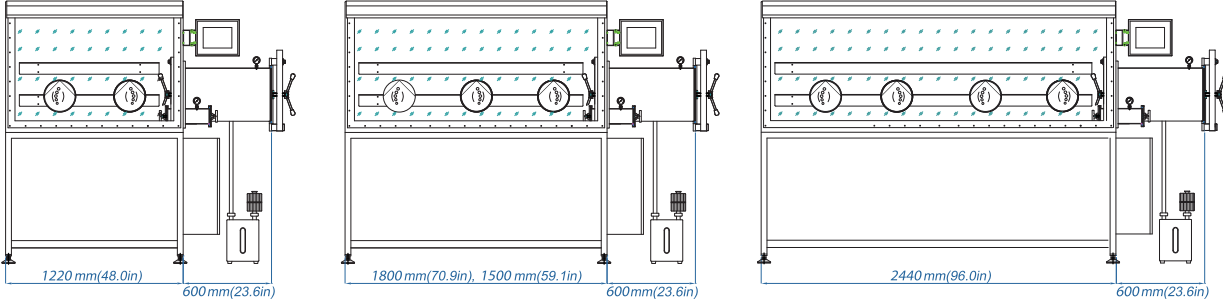

Module Combination

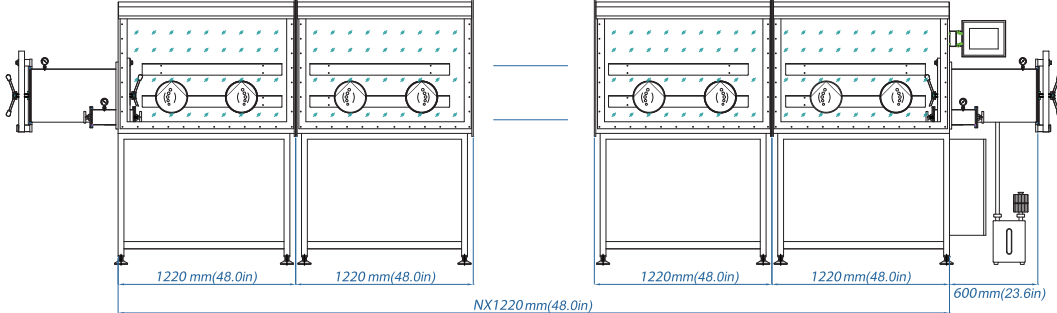

SEPARATE GAS PURIFICATION SYSTEM



FUNCTION

- Operation: Easy access to the glovebox
- Control: Manual or PLC controlled
- Power: 110V/50Hz or 220V/50Hz
- Working Gas: Nitrogen, Argon or Helium
- Regeneration gas: Working gas mixed with Hydrogen (5%-10%)



Type	MK100	MK200	MK300	MK400	MK500	MK600
Purifier	Single	Double	Single	Double	Single	Double
Main Pipe	DN40	DN40	DN50	DN50	DN63	DN63
Circulation Capacity	90m ³ /h	90m ³ /h	145m ³ /h	145m ³ /h	180m ³ /h	180m ³ /h
Copper Catalyst	5kg	2×5kg	9kg	2×9kg	12kg	2×12kg
Molecular Sieve	5kg	2×5kg	9kg	2×9kg	12kg	2×12kg

SOLVENT PURIFICATION SYSTEM

Applicable for solvent drying and purification by removing water, oxygen etc.

Low purity grade industrial solvents can be purified into high purity grade.

VTI provides materials replacement and regeneration services for purification columns.

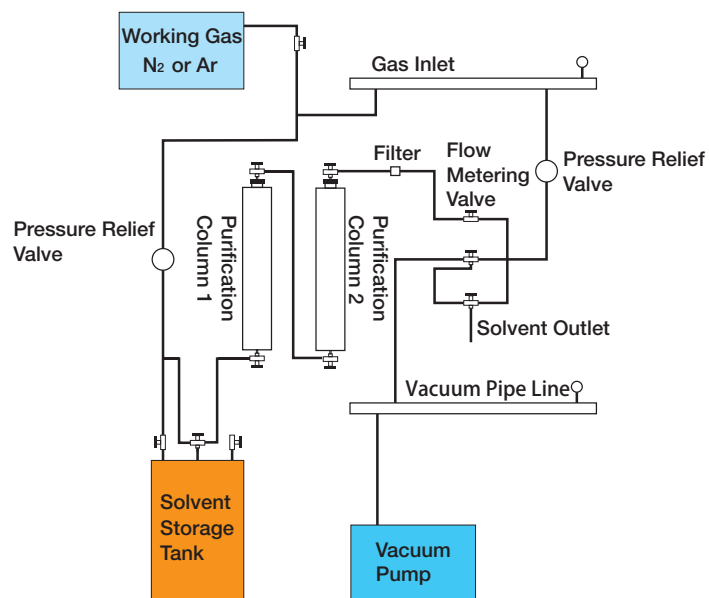
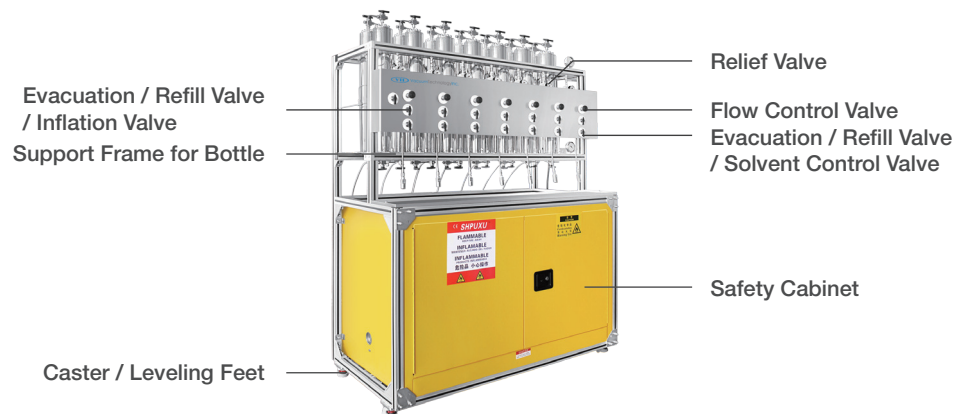

Treatable Solvent

Aromatic and Lipid	Pentane, n-Hexane, Cyclohexane, n- Heptane, Toluene, Benzene
Ethers	Diethyl Ether, THF, Dimethyl Ether
Chlorinated Solvent	Dichloromethane, Chloroform, Chlorobenzene
Amine Solvent	Triethylamine, Pyridine, N-di(isopropyl)ethylamine
Alcohol	Methanol, Ethanol
Other General Solvent	Acetonitrile(MeCN), DMF, Dimethyl Sulfoxide, Acetone

ACCESSORIES



Oxygen Analyzer

- Measuring range: 0 ~1000ppm
- ZrO₂ Sensor: Solid state sensor, long life, to be exposed in the air without consumption



Moisture Analyzer

- Measuring range: 0~500ppm
- P₂O₅ Sensor: Corrosion resistant, the sensor can be renewed by acid-cleaning while contaminated by HF or other corrosive atmosphere



Internal Solvent Trap

- Absorbent: 1.25 kg activated carbon
- Mounted inside the glovebox main chamber



Power Cord Feedthrough



Binding Posts Feedthrough



Gas/Fluid Feedthrough



BNC Feedthrough



USB Feedthrough



De-Electrostatic Unit

- Effectively remove localized static charges
- Effective ionization range: 12"
- Pulse rate and ionic balance controls allow for effective calibration and adjustment of the counter SPI to give optimum ion balance and output.



Microscope Unit

- Type: TV Microscope, 1/3" CCD color
- Magnification: Max. 300 times, continuously adjustable
- Monitor: PHILIPS 17", with flexible support
- Up and Down lighting source: LED ring
- Platform: Movable, easy to align the objective and center the lens



De-Dusting Unit

- With 2 filters, switchable
- Stainless steel shell
- Filter accuracy: 0.3µm
- High performance circulation unit
- Main pipe Stainless steel DN40 (KF40)



Refrigerator

- The door is inside the Glovebox
- Internal dimension:
(20L) L*W*H=250*200*400mm
(30L) L*W*H=300*220*450mm
- Lowest temperature: -30 °C
(-35 to -40°C available)



Heated Antechamber

- Maximum temperature: 250 °C
- With temperature controller



Hydrofluoric (HF) Acid Absorber

- Absorb hydrofluoric acid
- Mounted outside the glovebox



Dust Filter

- 0.30 μm



Oil Mist Filter

- For vacuum pump



Angle Valve

- Bellow sealed with pilot valve



Gloves

- 8B1532
(Other models available)



Vacuum Pump

- Rotary vane pump
- RV8 / RV12



Cold Well

- Fabricated through the floor of the Glovebox
- Stainless steel well
- Diameter: 150mm; depth 200mm (customized sizes on request)
- Dewar is filled with liquid nitrogen for low temperature work

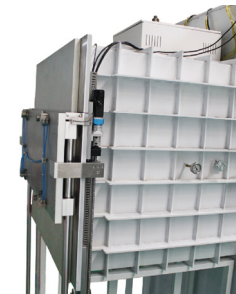

Rectangular Vacuum Chamber

- Vacuum up to 100Pa
- Both doors can be operated manually or automatically



Nitrogen Removal System

- Effectively remove nitrogen inside the glovebox when using argon as working gas
- Nitrogen content < 1 ppm

PRODUCTION EQUIPMENT



CNC Turning Center



Laser Cutting Machine



ABB Welding Robot



Machining Center



3D CMM



Wire Cut EDM



Helium Mass Spectrometer Leak Detector



Gantry CNC Machining Center



CNC Press Break



15 Great Republic Drive, Unit #4
Gloucester, Massachusetts 01930
USA

Phone: (978)879-4302

Fax: (978)879-4387

E-mail: sales@vti-glovebox.com

Website: www.vti-glovebox.com



Business card