

PRODUCT CATALOG

2019

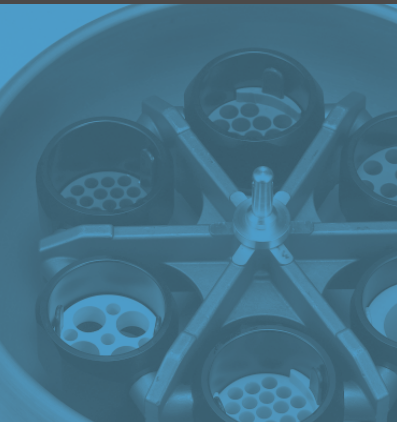

Sample Separation

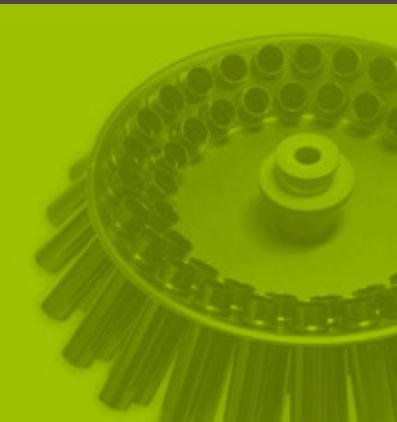

Sample Concentration



Sample Growing



Sample Storage



www.ihanil.com

60 years of Quality and Trust

Since 1958, Hanil Scientific Inc. has been keeping its core technology of making trust worthy centrifuges for all laboratory and medical uses. Major parts of Hanil Scientific centrifuges, including induction motors, rotors, and chassis are all manufactured and fabricated in-house and go through strict quality assurance processes. The ISO9001, ISO13485, and KGMP certified factory is equipped with the latest computerized tools and large-format CNC machines to provide a continuum of support for physical production for the models that demand the highest precision in the toughest condition. Along the latest tools added with proud Korean craftsmanship, Hanil strives to produce top-quality products with intuitive controls to provide the best laboratory systems for your setting.



Sample Separation

Centrifuge Overview - p.6

Rotor Selection Guide - p.10

Catalog Numbering Rule - p.13

Micro Centrifuges - p.14

Ultra Centrifuge - p.17

High Speed Centrifuges - p.20

Multi-purpose Centrifuges - p.27

Large Capacity Centrifuges - p.33

Clinical Centrifuges - p.38

Accessories - p.50

Industrial Centrifuges - p.56



Sample Concentration

Centrifugal Vacuum Concentrators - p.62

Freeze Dryers & Cooling Traps - p.70

Gas Purging Evaporation Concentrator - p.76

Sample Growing

Laboratory Fermentors - p.82

Photo Bioreactors - p.88

CO₂ Incubator - p.90

Sample Storage

Overview - p.96

Deep Freezers - p.98

Accessories - p.106

Sample Separation

Centrifuge Overview - p.6

Rotor Selection Guide - p.10

Catalog Numbering Rule - p.13

Micro Centrifuges

Smart R17 Plus / Smart 15 Plus - p.14

Smart 13 - p.15

Ultra Centrifuge

Ultra 5.0 - p.17

High Speed Centrifuges

Supra R30 - p.20 / Supra R22 - p.21

Supra R17 - p.22 / Supra R12 - p.23

Multi-purpose Centrifuges

Combi R515 - p.27 / Combi 508 - p.28

Large Capacity Centrifuges

Component R12 / Component R6 / Component wR - p.33

Clinical Centrifuges

Fleta 4 - p.38 / Fleta 5 - p.41

CellSpin - p.44 / SeroSpin II - p.46 / HematoSpin II - p.48

Accessories

Tube Racks (Adaptors) - p.50

Centrifuge Tubes - p.54

Industrial Centrifuges

J1250 - p.56

HA400 - p.59

Laboratory Centrifuge's Structure and Selection Criteria

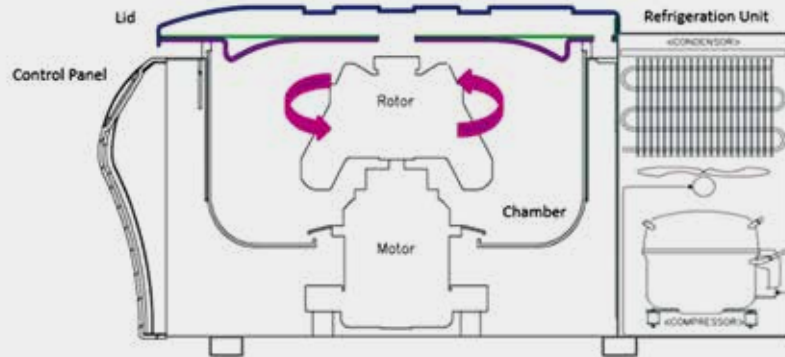

Purpose of Centrifugation

Precipitation, phase separation or density gradient

Depending on the goal of the centrifugation, proper rotor should be considered concurrently with the g-force to be applied into the sample.

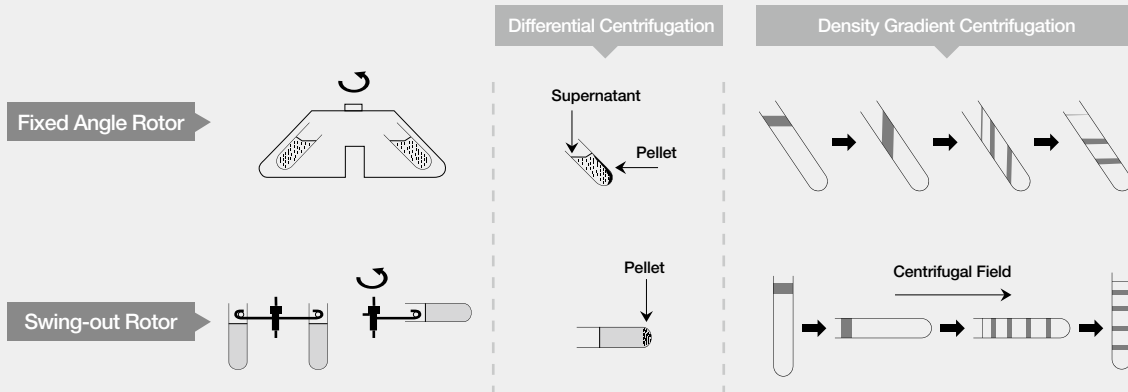

Max g-force to achieve complete separation

Not only the speed (RPM : Revolution Per Minute) of a centrifuge but also the RCF (Relative Centrifugal Force) of a rotor should be checked for the best result of centrifugation.

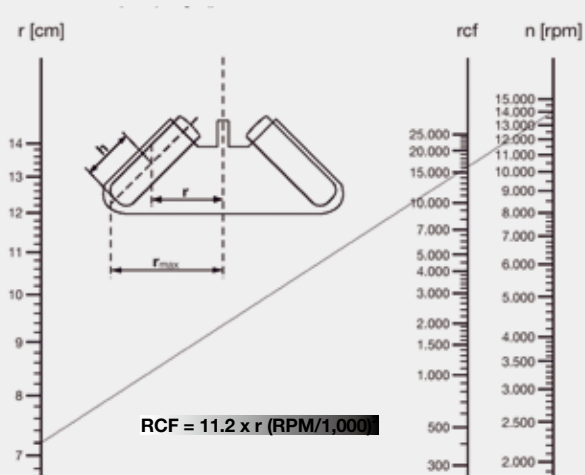

Temperature Control Method

According to the characteristic of a sample to be centrifuged, compressor cooled, passive refrigeration model or air-flow controlled model can be selected. When the samples are sensitive to over-ambient or fluctuating temperature, a refrigeration model is highly recommended.

Selection Guide of Hanil Centrifuges

Centrifuge Group		Micro			High Speed, Floor Standing					Multi-pupose, Table-top			Clinical Application, Swing-out			
Model		p.15	p.14	p.14	p.17	p.20	p.21	p.22	p.23	p.27	p.28	p.38	p.41	p.33	p.33	p.33
Max. RPM		13,500	15,000	17,000	50,000	30,000	22,000	17,000	12,000	15,000	8,000	4,000	-	-	-	-
Refrigeration		-	-	*	*	*	*	*	*	*	-	-	-	*	*	*
Vacuum		-	-	-	●	●	-	-	-	-	-	-	-	-	-	-

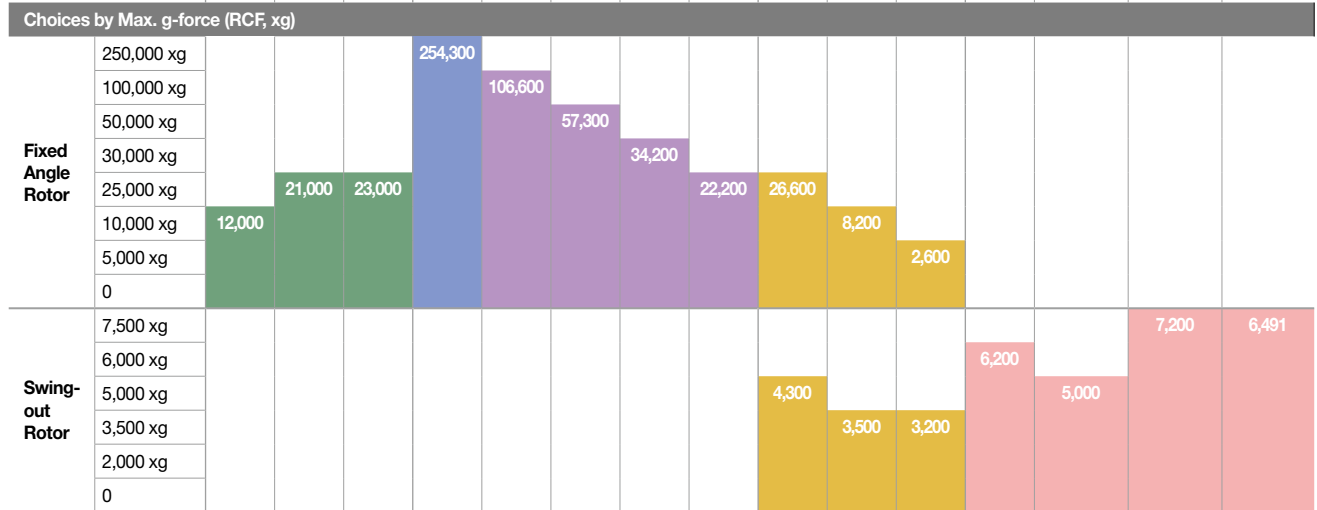

Choices by Sample Container

Sample Container	Smart 13	Smart 15 Plus	Smart R17 Plus	Ultra 5.0	Supra R30	Supra R22	Supra R17	Supra R12	Combi R515	Combi 508	Fleta 4	Fleta 5	Component wR	Component R6	Component R12
Micro Plates									S	S		S	S		
Micro Tubes									F	F					
PCR Strip	F	F	F						F	F					
0.2/0.5 ml	F	F	F		F	F	F		F	F					
1.5/2.0 ml	F	F	F	F	F	F	F		F	F					
Micro filter tube		F	F		F	F	F		F	F					
5 ml	F	F	F												
Tubes															
3/4 / 5 ml									S	S		S	S		
10/ 15 ml				F	F	F	F		F/S	F/S	F/S	S	S		
15 ml conical					F	F	F		F/S	F/S	F/S	S	S		
25 ml											S				
38.5 ml				F											
50 ml				F	F	F	F		F/S	F/S	S	S	S		
50 ml conical					F	F	F		F/S	F/S	S	S	S		
85 ml					F	F	F		F	F	S				
100 ml				F					S	S					
250 ml				F	F	F	F	F	F/S	S			S		
250 ml conical									S	S			S		
500 ml					F	F		F	S	S			S		
500 ml conical									S	S			S		
750 ml									S	S			S		
1,000 ml					F	F		F						S	
Syringe or PRP											S	S			
Blood Bags														S	S

* F stands for Fixed angle rotor and S for Swing-out rotor.

Features of Hanil Scientific's Laboratory Centrifuges

Premium Quality

- Accurate speed control less than 1.0% variance by high performance microprocessor, high torque AC induction motor, and various sensors
- Accurate temperature control by IC sensor and temperature offset function
- Unique motor drive system optimized in each rotation space
- Flexible or soft spindle drive system resulting in "self balancing" gyro moment for high speed models
- PABS (Positive Action Brake System) for stable and fast deceleration
- Dual ramp deceleration profile for keeping centrifuged samples at the best result
- Vacuum and sealing techniques to minimize air friction at super speed rotation
- Unique air flow structure for effective noise reduction and excellent cooling
- Unique anti-vibration damping structure for gentle operation
- Patented compressor damping structure to reduce vibration and maintain efficient separation
- Very finely fabricated motors, rotors, buckets, and accessories by Korean craftsmanship
- Very smooth tube insertion and removal through the precisely carved holes of rotors and buckets
- Accredited with ISO9001:2008, ISO13485, and KGMP
- Comply with CE conformity
- MFDS registered or certified as medical device

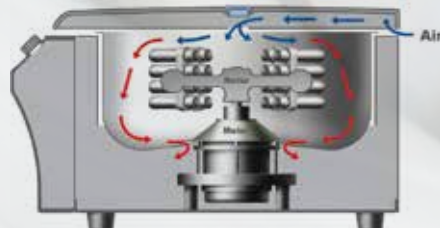
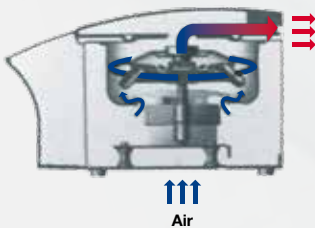
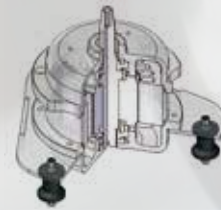
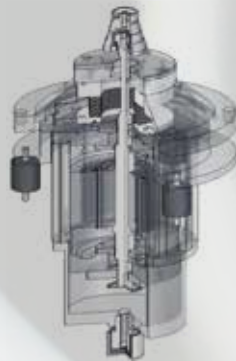
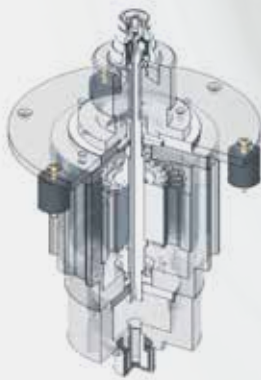

Superior Safety

- Durable chassis with steel armored chamber and steel layered lid
- Automatic interlock system to prevent rotor's spinning when lid is open
- Lid drop protected construction and fine control of lid opening
- Detection or alarm to sense imbalance, lid open, overspeed, low speed or over-heating
- Mounted with imbalance detection and tracking devices using by Hall sensor or limit switch
- Adjustable imbalance cutoff and tracking function
- Password enabled lock and unlock function in some models
- Automated rotor recognition system for the protection of over speed and improper operation
- User friendly emergency opening when black-out happens to retrieve sample safely
- Easy to clean surface and parts, autoclavable rotors and buckets for contamination free maintenance
- Maintenance-free, less heat-generating, noiseless, AC induction motor
- Cooled with CFC free, environmental friendly refrigerants

Greatest Convenience

- Single action of rotor coupling and decoupling only by rotor lid closure or opening (no need of any tool) for large sizes of Fixed Angle Rotors
- Self-lock rotor coupling, triggered by centrifugal force while spinning (Ultra model)
- Ergonomically arranged control and display
- Intuitive control panel and easy to read comprehensive displays with LED lights
- Automated rotor recognition scheme with automatic g-force calculation and display
- Automatic last run call and convenience to call, modify, or save data
- Stress-free lid opening and closure by smoothly motorized lid lock structure
- Effortlessly working emergency lid opening scheme to take sample out safely
- Easy to clean drainage from the chamber hole of refrigerated models
- Movable casters and adjustable feet

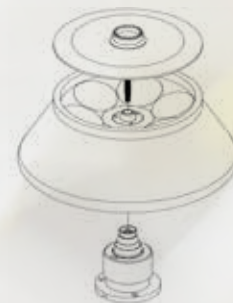













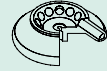



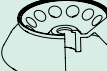

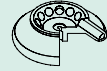



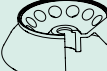
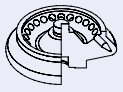
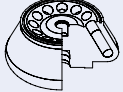
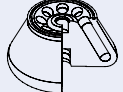

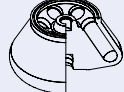
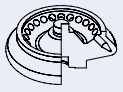
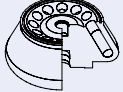
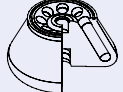

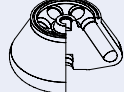
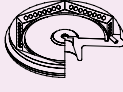

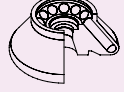
Single action of rotor coupling

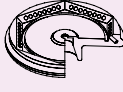

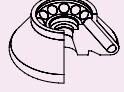
Self-lock-rotor coupling of Ultra 5.0

Selection Guide of Fixed Angle Rotor

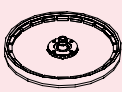
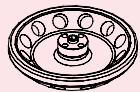
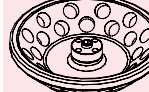
* Radius is the distance from the center of the rotor to the inner end of tube carrier in mm.

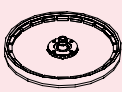
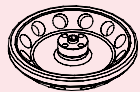
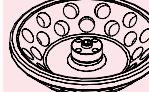
Micro Centrifuges								
Rotor Shape								
Cat. No.		A0.2-32	A0.2M-32	A2.0-12	A2.0M-18	A2.0M-24 / A2.0MP-24	A5.0-6	A5.0M-12
Rotor ID		-	2	-	3	1	-	4
Max. Capacity		32 x 0.2 mL	32 x 0.2 mL	12 x 1.5/2.0 mL	18 x 1.5/2.0 mL	24 x 1.5/2.0 mL	6 x 5.0 mL	12 x 5.0 mL
Bore Ø x L (mm)		6.5 x 15	6.5 x 17	11.5 x 38	11 x 38	11 x 38	16.5 x 28.5	17 x 53.8
Radius* (mm)		Inner line : Min. 31.13 / Max. 44.06 Outer line : Min. 46.13 / Max. 55.68	55.5	59	71.2	83.7	52	81
Max. height for tube fit (mm)		-	-	48	53.5	56	16.5	41
Smart R17 Plus	Max. RPM Max. RCF	-	12,500 9,695 xg	-	17,000 23,005 xg	15,000 21,055 xg	-	15,000 20,376 xg
Smart 15 Plus		-	-	-	15,000 17,910 xg	-	-	
Smart 13		6,000 Inner line : 1,253~1,773 Outer line : 1,857~2,241 xg	-	13,500 12,032 xg	-	-	6,000 2,616 xg	-
Ultra Centrifuge								
Rotor Shape								
Cat. No.		A2.0U-24	A10U-12	A13.5U-8	A13.5U-12	A38.5U-6		
Rotor ID		3	4	5	1	9		
Max. Capacity		24 x 1.5/2.0 mL	12 x 10 mL	8 x 13.5 mL	12 x 13.5 mL	6 x 38.5 mL		
Bore Ø x L (mm)		11 x 37.5	17 X 70	16.3 X 83	16.3 X 83.4	25.6 x 92		
Radius* (mm)		82	85	73	87	91		
Max. height for tube fit (mm)		47.1	71.5	84.4	83.4	98.9		
Ultra 5.0	Max. RPM Max. RCF	40,000 146,680 xg	45,000 192,430 xg	50,000 204,030 xg	50,000 243,160 xg	50,000 254,340 xg		
High Speed Centrifuges / Multi-purpose Centrifuges								
Rotor Shape								
Cat. No.		A0.2-48	A2.0-24	A2.0-36	A10-12	A15-12	A15c-12	
Rotor ID		18	1	14	2	4	8	
Max. Capacity		48 x 0.2 mL	24 x 1.5/2.0 mL	36 x 1.5/2.0 mL	12 x 10 mL	12 x 15 mL	12 x 15 mL conical	
Bore Ø x L (mm)		6.5 x 17	11.5 x 38	11 x 37.5	16.3 x 74.5	17 x 96	17 X 115	
Radius* (mm)		88.9	80.8	115.7	85.1	106	99.4	
Max. height for tube fit (mm)		-	46	49.5	87.1	120.8	123.2	
Supra R30	Max. RPM Max. RCF	-	-	20,000 51,741 xg	30,000 85,628 xg	30,000 106,657 xg	17,000 32,116 xg	
Supra R22		-	-	18,000 41,910 xg	22,000 46,049 xg	22,000 57,358 xg	17,000 32,116 xg	
Supra R17		-	-	15,000 29,104 xg	17,000 27,496 xg	17,000 34,249 xg	15,000 25,004 xg	
Supra R12		-	-	-	-	-	-	
Combi R515		12,500 15,530 xg	15,000 20,325 xg	14,000 25,353 xg	15,000 21,407 xg	15,000 26,664 xg	15,000 25,004 xg	
Combi 508		8,000 6,361 xg	8,000 5,781 xg	8,000 8,279 xg	8,000 6,089 xg	8,000 7,585 xg	8,000 7,105 xg	
Combi 508		8,000 6,361 xg	8,000 5,781 xg	8,000 8,279 xg	8,000 6,089 xg	8,000 7,585 xg	8,000 7,105 xg	
Clinical Centrifuges								
Rotor Shape								
Cat. No.		A-cyto-12	A-sero-12(A) / A-sero-12(B)	A-hemo-24	AL15-12	AL15-24		
Rotor ID		-	-	-	3	4		
Max. Capacity		12 slides x 0.5~0.6 mL	12 x 75 mm	24 x 0.07 mL capillary	12 x 15 mL	24 x 15 mL		
Bore Ø x L (mm)		-	-	-	18 x 94.5	18 x 104.5		
Radius* (mm)		116.8	86.5	96.5	142.4	155.8		
Max. height for tube fit		-	-	-	134	143.3		
Fleta 4	Max. RPM Max. RCF	-	-	-	4,000 2,395 xg	4,000 2,635 xg		
CellSpin		3,000 1,175 xg	-	-	-	-		
SeroSpin II		-	3,400 1,118 xg	-	-	-		
HematoSpin II		-	-	12,000 15,536 xg	-	-		
HematoSpin II		-	-	12,000 15,536 xg	-	-		

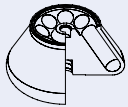

A50U-8

6
8 x 50 mL
29 x 100.5
98
107.3
30,000
98,784 xg

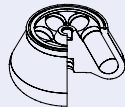

A94U-6

7
6 x 94 mL
38.5 x 105
99.4
110.7
35,000
136,377 xg

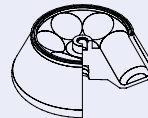

A250U-6

8
6 x 250 mL
60 x 101
129
105.8
20,000
57,792 xg

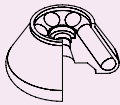

A50-6

5
6 x 50 mL
29 x 100
96.1
122.7
30,000
96,696 xg
22,000
52,001 xg
17,000
31,050 xg
-

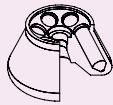

A50c-6

6
6 x 50 mL conical
30 x 108.6
91
118.5
17,000
29,402 xg
17,000
29,402 xg
15,000
22,891 xg
-

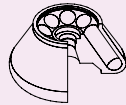

A50-8

7
8 x 50 mL
29 x 100
98.9
110.7
30,000
99,513 xg
20,000
44,228 xg
15,000
24,878 xg
-

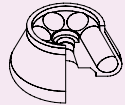

A85-6

9
6 x 85 mL
38.3 x 95
97.6
115.5
25,000
68,198 xg
20,000
43,647 xg
15,000
24,551 xg
-

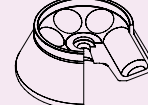

A250-6

10
6 x 250 mL
62 x 103
138.3
132
10,000
15,462 xg
12,000
22,265 xg
12,000
22,265 xg

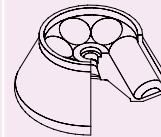

A500-6

11
6 x 500 mL
70 x 141
158.7
168.5
8,000
11,355 xg
9,000
14,372 xg
-

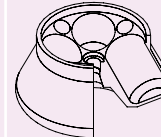

A1000-4

12
4 x 1,000 mL
98 x 144
169.9
184.8
7,000
9,307 xg
8,000
12,157 xg
8,000
12,157 xg

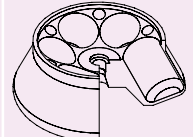

A1000-6

13
6 x 1,000 mL
98 x 144
200.1
176.5
-

15,000
24,174 xg
8,000
6,876 xg

15,000
22,891 xg
8,000
6,511 xg

15,000
24,878 xg
8,000
7,077 xg

15,000
24,551 xg
8,000
6,983 xg

8,000
9,896 xg

10,000
17,743 xg

8,000
12,157 xg

7,000
10,962 xg

Selection Guide of Swing-out Rotor

* Radius is the distance from the center of the rotor to the inner end of tube carrier in mm.

Large Capacity Centrifuges		Rotor Shape		Rotor Shape		Rotor Shape		
		WS2400-6		WS1000-6		WS750-6		
Rotor Shape								
Cat. No.		WS2400-6		WS1000-6		WS750-6		
Bucket Cat. No.		B2400		B1000 / B1000S		B750 / B750S		TM96(750-6)
Max. Capacity		6 x 2 x 500 mL		6 x 1,000 mL		6 x 750 mL		6 x 4 MTPs
Radius* (mm)		290		259.8		225		191.9
Max. height for tube fit (mm)		209.2		182.2 (w/o cap), 169.5 (w/ cap)		161.5 (w/o cap), 129 (w/ cap)		88 x 128.5 x 42
Component R12		4,500 6,491 xg		-		-		-
Component R6		-		5,000 7,261 xg		-		-
Component wR		-		-		4,500 5,096 xg		4,500 4,345 xg
Multi-purpose Centrifuges		Rotor Shape		Rotor Shape		Rotor Shape		Rotor Shape
		S750-4		S500-4		S500-4		S500-4
Rotor ID		13		12		12		12
Bucket Cat.No.		B750 / B750S		TM96(750-4)		B500		TM96(500-4)
Max. Capacity		4 x 750 mL		4 x 4 MTPs		4 x 500 mL		4 x 4 MTPs
Radius* (mm)		196.5		163.5		194		154
Max. height for tube fit (mm)		157.5 (w/o cap), 142 (w/ cap)		88 x 128.5 x 42		157.2 (w/o cap), 143.5 (w/ cap)		87 x 128.5 x 53
Combi R515		4,000 3,515 xg		4,000 2,925 xg		4,500 4,392 xg		4,000 2,755 xg
Combi 508		-		-		4,000 3,435 xg		4,000 2,755 xg
Clinical Centrifuges		Rotor Shape		Rotor Shape		Rotor Shape		Rotor Shape
		HSR-4S		S85-4		S50-6		HSM-2
Rotor ID		3		2		1		1
Bucket Cat.No.		HBTM		HBT50-1		HBT50-2		HBT50c-1
Max. Capacity		4 x 8 x 15(16) mL		4 x 50 mL		4 x 2 x 50 mL		4 x 50 mL conical
Radius* (mm)		164.1		181.3		181.3		184.2
Max. height for tube fit (mm)		67.5		154.3		154.3		143.4
Fleta 5		3,000 1,651 xg		5,500 6,131 xg		4,500 4,104 xg		5,500 6,230 xg
Fleta 4		-		-		-		4,000 2,910 xg
Bucket Cat.No.		B85		B50		B15c-2		-
Max. Capacity		4 x 85 mL		6 x 50 mL		6 x 2 x 15 mL conical		2 (MTP/ Cell Culture/DWP)
Radius* (mm)		172.6		181.3		165.8		139
Max. height for tube fit (mm)		142.5		145.7		138.7		127.3 x 88 x 110
Fleta 5		-		-		-		2,000 622 xg
Fleta 4		4,000 3,087 xg		4,000 3,243 xg		4,000 2,966 xg		-

Catalog Numbering Rule of Centrifuge and Accessories

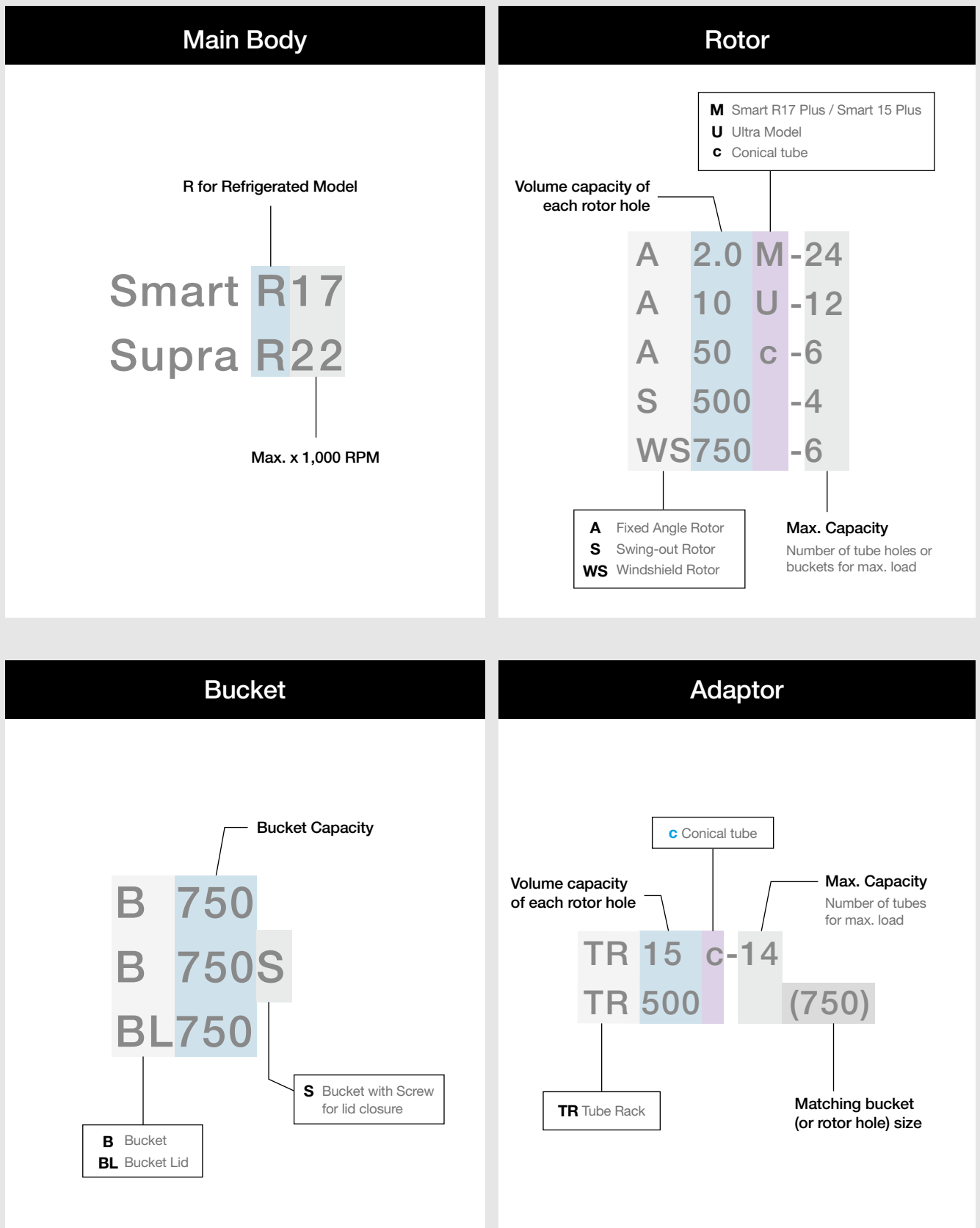

There may be exceptions to the rule. For more information, refer to the specific pages of model.

Micro Centrifuges

Smart R17 Plus / Smart 15 Plus / Smart 13

Micro Centrifuges

Smart R17 Plus / Smart 15 Plus

- Rapid acceleration and deceleration to speed up molecular works
- Plastic, snap-fit button lid of 24 hole rotor for convenient and time saving usage
- Ideal for very quiet and speedy operation
- Easy to read graphical LCD display
- Easy to clean specially coated glossy surface
- Compact, light-weighted, and ergonomic design
- Smooth operation completed with motorized lid opening and closure
- Distinct "Fast Cool" button in a refrigerated model



A2.0M-24

A2.0M-18

A0.2M-32

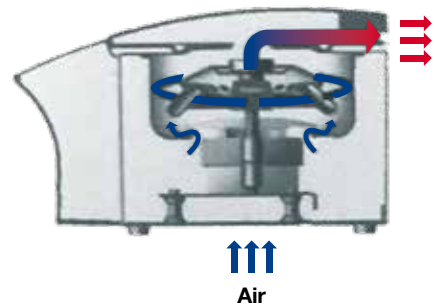

Non-refrigerative Smart 15 Plus
with uniquely controlled air cooling structure



Smart R17 Plus



Smart 15 Plus

Micro Centrifuge

Smart 13

- Ideal for simple and efficient spinning at high speed
- Very quiet operation even at max speed of 13,500 rpm
- Rotating knobs enable quick setting of time and speed
- Can be terminated in 8 secs even at max speed
- Any types of micro tubes up to 2.0 mL can be loaded.
- Interchangeable optional PCR rotor for four 8-tube strips
- A sensitive hall sensor can activate a safety stop when lid is opened.
- Well-designed, non-slip silicone rubber feet
- Light weight and portable unit



A2.0-12



A0.2-32

Technical Specifications

		Smart R17 Plus	Smart 15 Plus	Smart 13
Speed RCF (xg)	Max. RPM / Fixed angle	17,000 rpm	15,000 rpm	13,500 rpm
	Max. RCF / Fixed angle	23,005 xg	21,055 xg	12,032 xg
Max. capacity / Fixed angle		12 x 5.0 mL, 24 x 1.5/2.0 mL, 4 PCR strips		6 x 5.0 mL 12 x 1.5/2.0 mL, 4 PCR strips
ACC/DEC	ACC/DEC ramps	9/10 steps / *5/6 steps	9/10 steps	-
	Acc. time to max. speed	≤ 15 sec		≤ 18 sec
	Dec. time from max. speed	≤ 15 sec		≤ 8 sec
Temperature	Temperature range	-10°C to 40°C	-	-
	Fast cool	Yes	-	-
Time control		< 100 min, pulse, continuous	< 100 min, pulse, continuous	≤15 min, pulse
Program memory		10	10	-
Noise level		< 60 dB		
Imbalance cutoff / tracking		Yes		-
Rotor identification		manual		-
Dimension (W x D x H, mm)		285.2 x 593.3 x 281	293 x 380 x 242	189.7 x 202 x 129
Weight without rotor		33 kg	15 kg	1.5 kg
Power consumption		1.5 kVA	500va	0.1KW
Power input (V, Hz)		220V, 60HZ		
Cat. No.		SM-R17PL	SM-15PL	SM-13











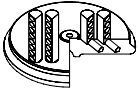

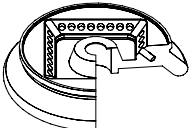

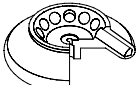





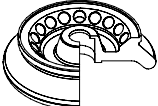







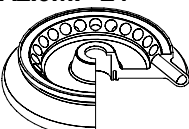

* Registered as medical device at MFDS¹⁾

¹⁾ MFDS : Ministry of Food and Drug Safety (KOREA)

Micro Centrifuges

Smart R17 Plus / Smart 15 Plus / Smart 13

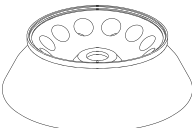
Fixed Angle Rotors for Micro Centrifuges

Rotor	Adaptable Centrifuge	Tube Capacity	Required Adaptor	Bore Ø x L (mm) Radius (mm)	Max. RPM (rpm) Max. RCF (xg)
A0.2-32 (PCR Strip Rotor)  Hole angle : $\angle 45^\circ$ Max. Capacity : 32 x 0.2 mL Size (Ø x H) : Ø124 x 22 mm	Smart 13	 0.2 mL	-	6.5 x 15 Inner line : 31.13 (Min.) 44.06 (Max.) Outer line : 46.13 (Min.) 55.68 (Max.)	6,000 Inner line : 1,253-1,773 Outer line : 1,857-2,241
		 0.2 mL strips	-		
A0.2M-32 (PCR Strip Rotor)  Hole angle : $\angle 45^\circ$ Max. Capacity : 32 x 0.2 mL Size (Ø x H) : Ø172 x 38.5 mm	Smart R17 Plus	 0.2 mL	-	6.5 x 17 55.5	12,500 9,695
	Smart 15 Plus	 0.2 mL strips	-		
A2.0-12  Hole angle : $\angle 45^\circ$ Max. Capacity : 12 x 1.5/2.0 mL Size (Ø x H) : Ø124 x 37 mm Max. height for tube fit : 48 mm	Smart 13	 1.5/2.0 mL	-	11.5 x 38 59	13,500 12,032
		 0.5 mL	TR0.5 	8 x 37 59	
		 0.2 mL	TR0.2 	6 x 21 44	
A2.0M-18  Hole angle : $\angle 45^\circ$ Max. Capacity : 18 x 1.5/2.0 mL Size (Ø x H) : Ø147 x 38.5 mm Max. height for tube fit : 53.5 mm Incl. a lid	Smart R17 Plus	 1.5/2.0 mL Micro-filter tube	-	11 x 38 71.2	17,000 23,005
		 0.5 mL	TR0.5 	8 x 37 66	17,000 21,325
		 0.2 mL	TR0.2 	6 x 21 56	17,000 18,094
	Smart 15 Plus	 1.5/2.0 mL Micro-filter tube	-	11 x 38 71.2	15,000 17,910
		 0.5 mL	TR0.5 	8 x 37 66	15,000 16,602
		 0.2 mL	TR0.2 	6 x 21 56	15,000 14,087
A2.0M-24 A2.0MP-24  Hole angle : $\angle 45^\circ$ Max. Capacity : 24 x 1.5/2.0 mL Size (Ø x H) : Ø172 x 38.5 mm Max. height for tube fit : 56 mm Incl. a lid A2.0MP-24 incl. plastic lid	Smart R17 Plus	 1.5/2.0 mL	-	11 x 38 83.7	15,000 21,055
	Smart 15 Plus	 0.5 mL	TR0.5 	8 x 37 78.5	15,000 19,747
		 0.2 mL	TR0.2 	6 x 21 68.5	15,000 17,231
A5.0-6  Hole angle : $\angle 50^\circ$ Max. Capacity : 6 x 5.0 mL Size (Ø x H) : Ø104 x 37.4 mm Max. height for tube fit : 60 mm Incl. a lid	Smart 13	 5.0 mL	-	17 x 25.5 65	6,000 2,616
A5.0M-12  Hole angle : $\angle 50^\circ$ Max. Capacity : 12 x 5.0 mL Size (Ø x H) : Ø167.2 x 57.4 mm Max. height for tube fit : 60 mm Incl. a lid	Smart R17 Plus Smart 15 Plus	 5.0 mL	-	16.5 x 61 83.5	15,000 20,376

* Radius : From the center of the rotor to the inner end of tube carrier.

Ultra Centrifuge

Ultra 5.0

- Ideal for DNA, RNA, and protein separation
- 12 x 13.5 mL and 6 x 38.5 mL rotors up to 50,000 rpm (243,000 xg and 254,000 xg)
- Large capacity, 6 x 250 mL rotor up to 25,000 rpm (90,000 xg)
- High torque AC induction motor
- Self-lock rotor coupling, triggered by centrifugal force while spinning
- Vacuum and sealing constructed to minimize air friction at super speed rotation
- Automatic rotor identification by photo sensor
- Intuitive control panel with safety warning LEDs
- Robust and safe sliding lid



- Direct and flexible spindle drive system to endure ultra speed
- Unique anti-vibration damping structures embedded in both inside and outside motor



Ultra Centrifuge

Ultra 5.0

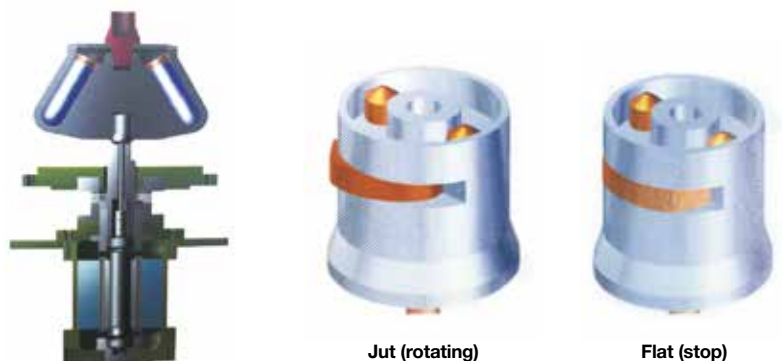

Very convenient self-lock rotor coupling, triggered by centrifugal force while spinning

Technical Specifications

		Ultra 5.0
Speed	Max. RPM / Fixed angle	50,000 rpm
RCF (xg)	Max. RCF / Fixed angle	254,340 xg
Max. capacity / Fixed angle		6 x 250 mL
ACC/DEC		10/10 steps
Temperature range		-10°C to 40°C
Time control		< 100 hr, continuous
Program memory		100
Noise level		≤ 65 dB
Vacuum system		Yes
Rotor identification		Automatic
Dimension (W x D x H, mm)		710 x 1,000 x 1,260
Weight without rotor		450 kg
Power consumption		5.0 kVA
Power input (V, Hz)		220V+ / 60 Hz (110V, 50 Hz optional)
Cat. No.		UL-5.0











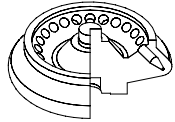

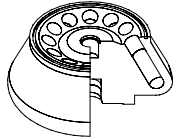

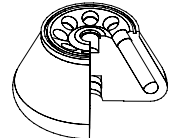

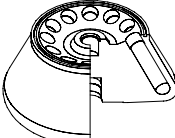
A38.5U-8

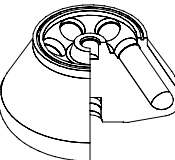

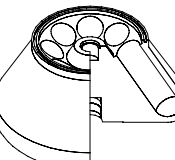
A2.0U-24

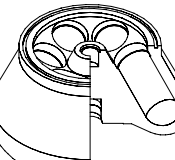
Fixed Angle Rotors for Ultra 5.0

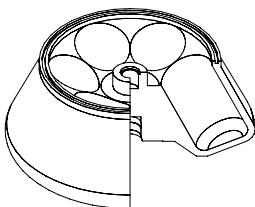
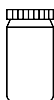
Rotor	Tube Capacity Bottom Type	Bore Ø x L (mm) Radius (mm)	Max. RPM (rpm) Max. RCF (xg)
A2.0U-24  <p>Hole angle : $\angle 40^\circ$ Max. Capacity : 24 x 1.5/2.0 mL Size (Ø x H) : $\phi 180 \times 88$ mm Max. height for tube fit : 47.1 mm Incl. a screw type lid</p>	 1.5/2.0 mL -	11 x 37.5 82	40,000 146,680
A10U-12  <p>Hole angle : $\angle 26^\circ$ Max. Capacity : 12 x 10 mL Size (Ø x H) : $\phi 180 \times 90$ mm Max. height for tube fit : 71.5 mm Incl. a screw type lid</p>	 10 mL Round	17 X 70 85	45,000 192,430
A13.5U-8  <p>Hole angle : $\angle 26^\circ$ Max. Capacity : 8 x 13.5 mL Size (Ø x H) : $\phi 165.5 \times 91.3$ mm Max. height for tube fit : 84.4 mm Incl. a screw type lid</p>	 13.5 mL Round	16.3 X 83 73	50,000 204,030
A13.5U-12  <p>Hole angle : $\angle 26^\circ$ Max. Capacity : 12 x 13.5 mL Size (Ø x H) : $\phi 189 \times 90.5$ mm Max. height for tube fit : 83.4 mm Incl. a screw type lid</p>	 13.5 mL Round	16.3 X 83.4 87	50,000 243,160
A38.5U-6  <p>Hole angle : $\angle 29^\circ$ Max. Capacity : 6 x 38.5 mL Size (Ø x H) : $\phi 198 \times 112$ mm Max. height for tube fit : 98.9 mm Incl. a screw type lid</p>	 38.5 mL Round	25.6 x 92 91	50,000 254,340
A50U-8  <p>Hole angle : $\angle 30^\circ$ Max. Capacity : 8 x 50 mL Size (Ø x H) : $\phi 213 \times 110$ mm Max. height for tube fit : 107.3 mm Incl. a screw type lid</p>	 50 mL Round	29 x 100.5 98	30,000 98,784
A94U-6  <p>Hole angle : $\angle 25^\circ$ Max. Capacity : 6 x 94 mL Size (Ø x H) : $\phi 219.7 \times 119$ mm Max. height for tube fit : 110.7 mm Incl. a screw type lid</p>	 94 mL Round	38.5 x 105 99.4	35,000 136,377
A250U-6  <p>Hole angle : $\angle 25^\circ$ Max. Capacity : 6 x 250 mL Size (Ø x H) : $\phi 280 \times 130$ mm Max. height for tube fit : 126.9 mm Incl. a screw type lid</p>	 250 mL Flat	60 x 101 129	20,000 57,792

* Radius : From the center of the rotor to the inner end of tube carrier.

High Speed Centrifuges

Supra R30 / Supra R22 / Supra R17 / Supra R12

High Speed Centrifuge

Supra R30

- Ideal for sub-cellular organelle separation
- Exceptional usage for 8 x 50 mL up to 30,000 rpm (almost 100,000 xg)
- Convenient rotor coupling and decoupling complete with rotor lid closure and opening (no need additional tool)
- Maintenance free durable induction motor
- Soft motor shaft for stable rotation of heavy rotors
- Automatic half-atmosphere vacuum control at over 22,000 rpm
- Intuitive control panel with safety warning LEDs
- Imbalance cut-off function for safe operation
- Robust and safe sliding lid



A1000-4



A250-6



A50-8



A50c-6

High Speed Centrifuge

Supra R22

- Affordable high speed centrifuge for usage of 4 x 1,000 mL
- Capacity for 6x50ml up to 22,000 rpm (52,000 xg) and 4 x 1000 mL at 8,000 rpm (12,000 xg)
- Convenient rotor coupling and decoupling in one single action of rotor lid closure and opening (no any tool is needed)
- Imbalance cutoff and tracking function
- Automatic rotor identification for safe operation
- Smoothly working, motorized lid opening and closure
- Excellent temperature control
- Password lock function



A1000-4



A50-6



A15-12

High Speed Centrifuges

Supra R30 / Supra R22 / Supra R17 / Supra R12

High Speed Centrifuge

Supra R17

- Economical choice for daily high speed centrifuge usage
- It is recommended to use conical 50 mL tubes at high speed (15,000 rpm / 22,000 xg)
- For up to 17,000 rpm (31,000 xg) with 6 x 50 mL tubes and 10,000 rpm (15,000 xg) with 6 x 250 mL tubes
- Fast cooling function to 4°C in 5 minutes for fast startup of cooled samples
- Convenient rotor coupling and decoupling with one single action of rotor lid closure and opening (no need of any tool)
- Intuitive control interface with numeric input buttons allows easy setting and editing of running conditions
- Selectable time counting control, at set speed or from starting
- Imbalance cutoff function for safe operation
- Compact, small foot print design



A250-6



A50c-6



A15-12



A15c-12

High Speed Centrifuge

Supra R12

- Recommended for large volume samples at high speed
- Capacity of 6 x 250 mL to 12,000 rpm (22,000 xg)
- Imbalance cut-off and tracking
- Intuitive and easy to control with extensive and informative display
- Smooth operation with motorized lid opening and closure
- Cooled with CFC free, environmental friendly refrigerant
- Excellent temperature control
- Password lock function



A1000-6



A500-6



A250-6











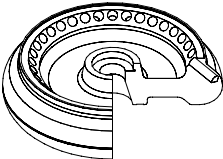















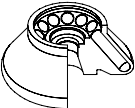

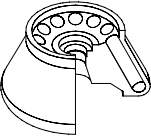

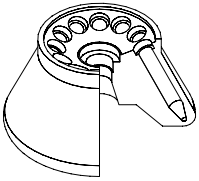

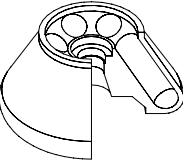





Technical Specifications

		Supra R30	Supra R22	Supra R17	Supra R12
Speed	Max. RPM / Fixed angle	30,000 rpm	22,000 rpm	17,000 rpm	12,000 rpm
	RCF (xg)	106,657 xg	57,358 xg	34,249 xg	22,265 xg
Max. capacity	Max. RCF / Fixed angle	4 x 1,000 mL	4 x 1,000 mL	6 x 250 mL	6 x 1,000 mL
	Fixed angle				
ACC/DEC ramps		10/10 steps		9/10 steps	10/10 steps
Temperature	Temperature range	-10°C to 40°C	-10°C to 40°C	-20°C to 40°C	-10°C to 40°C
	Fast cool	-	-	Yes	-
Time control		< 100 hr, continuous		Pulse Timed < 10 hr continuous	Pulse Timed < 100 hr, continuous
Program memory		100			
Noise level		≤ 65 dB		≤ 60 dB	≤ 65 dB
Vacuum system		Yes	-	-	-
Imbalance cutoff / tracking		Yes / -	Yes / Yes	Yes / -	Yes / Yes
Rotor identification		manual	Automatic	Automatic	Automatic
Dimension (W x D x H, mm)		710 x 1,000 x 1,260	668.7 x 800.6 x 891.3	473 x 611 x 840	668.7 x 800.6 x 891.3
Weight without rotor		415 kg	230 kg	114 kg	230 kg
Power consumption		5.2 kVA	5.1 kVA	2.9 kVA	3.9 kVA
Power input (V, Hz)		210~240V 60 Hz (110V, 50 Hz optional)		220V 50/60 Hz (110V optional)	210~240V 50/60 Hz (110V optional)
Cat. No.		SU-R30	SU-R22	SU-R17	SU-R12

High Speed Centrifuges











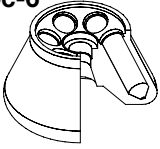

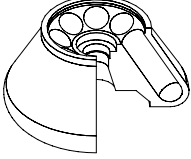















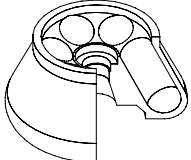

















Supra R30 / Supra R22 / Supra R17 / Supra R12

Fixed Angle Rotors for Supra Series (1)

Rotor	Adaptable Centrifuge	Tube Capacity Bottom Type	Required Adaptor	Bore Ø x L (mm) Radius (mm)	Max. RPM (rpm) Max. RCF (xg)
A2.0-36  Hole angle : $\angle 30^\circ$ Max. Capacity : 36 x 1.5/2.0 mL Size (ø x H) : ø240 x 64 Max. height for tube fit : 49.5 mm Incl. a coupling bolt lid	Supra R30	 1.5/2.0 mL Micro-filter tube	-	11 x 37.5 115.7	20,000 51,741
		 0.5 mL	TR0.5 	8 x 37 111	20,000 49,639
		 0.2 mL	TR0.2 	6 x 21 100	20,000 44,720
	Supra R22	 1.5/2.0 mL Micro-filter tube	-	11 x 37.5 115.7	18,000 41,910
		 0.5 mL	TR0.5 	8 x 37 111	18,000 40,208
		 0.2 mL	TR0.2 	6 x 21 100	18,000 36,223
	Supra R17	 1.5/2.0 mL Micro-filter tube	-	11 x 37.5 115.7	15,000 29,104
		 0.5 mL	TR0.5 	8 x 37 111	15,000 27,922
		 0.2 mL	TR0.2 	6 x 21 100	15,000 25,155
A10-12  Hole angle : $\angle 36^\circ$ Max. Capacity : 12 x 10 mL Size (ø x H) : ø179.9 x 82 Max. height for tube fit : 87.1 mm Incl. a coupling bolt lid	Supra R30	 10 mL Round	-	16.3 x 74.5 85.1	30,000 85,628
	Supra R22		22,000 46,049		
	Supra R17		17,000 27,496		
A15-12  Hole angle : $\angle 30^\circ$ Max. Capacity : 12 x 15 mL Size (ø x H) : ø222.7 x 106 mm Max. height for tube fit : 121 mm Incl. a coupling bolt lid	Supra R30	 15 mL Round	-	17 x 96 106	30,000 106,657
	Supra R22		22,000 57,358		
	Supra R17		17,000 34,249		
A15c-12  Hole angle : $\angle 25^\circ$ Max. Capacity : 12 x 15 mL conical Size (ø x H) : ø215 x 121 Max. height for tube fit : 123.2 mm Incl. a coupling bolt lid	Supra R30	 15 mL Conical	-	17 X 115 99.4	17,000 32,116
	Supra R22		17,000 32,116		
	Supra R17		15,000 25,004		
A50-6  Hole angle : $\angle 30^\circ$ Max. Capacity : 6 x 50 mL Size (ø x H) : ø200 x 109 mm Max. height for tube fit : 122.7 mm Incl. a coupling bolt lid	Supra R30	 50 mL Round	-	29 x 100 96.1	30,000 96,696
		 15 mL Round	TR15(50) 	17 x 94 89.9	30,000 90,475
		 15 mL Conical	TR15c(50) 	17 x 105 91	30,000 91,564
	Supra R22	 50 mL Round	-	29 x 100 96.1	22,000 52,001
		 15 mL Round	TR15(50) 	17 x 94 89.9	22,000 48,646
		 15 mL Conical	TR15c(50) 	17 x 105 91	22,000 49,241
	Supra R17	 50 mL Round	-	29 x 100 96.1	17,000 31,050
		 15 mL Round	TR15(50) 	17 x 94 89.9	17,000 29,047
		 15 mL Conical	TR15c(50) 	17 x 105 91	17,000 29,402

* Radius : From the center of the rotor to the inner end of tube carrier.

Fixed Angle Rotors for Supra Series (2)







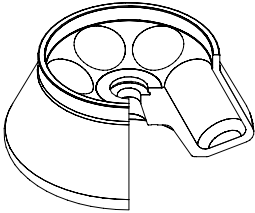

Rotor	Adaptable Centrifuge	Tube Capacity Bottom Type	Required Adaptor	Bore Ø x L (mm) Radius (mm)	Max. RPM (rpm) Max. RCF (xg)	
A50c-6  Hole angle : $\angle 23^\circ$ Max. Capacity : 6 x 50 mL conical Size (ø x H) : ø205.7 x 119 mm Max. height for tube fit : 118.5 mm Incl. a coupling bolt lid	Supra R30	 50 mL Conical	-	30 x 108.6 91	17,000 29,402	
	Supra R22		-		17,000 29,402	
	Supra R17		-		15,000 22,891	
A50-8  Hole angle : $\angle 30^\circ$ Max. Capacity : 8 x 50 mL Size (ø x H) : ø213 x 110.7 mm Max. height for tube fit : 110.7 mm Incl. a coupling bolt lid	Supra R30	 50 mL Round	-	29 x 100 98.9	30,000 99,513	
		 15 mL Round	TR15(50) 	17 x 94 92.8	30,000 93,375	
		 15 mL Conical	TR15c(50) 	17 x 105 93.9	30,000 94,482	
	Supra R22	 50 mL Round	-	29 x 100 98.9	20,000 44,228	
		 15 mL Round	TR15(50) 	17 x 94 92.8	20,000 41,500	
		 15 mL Conical	TR15c(50) 	17 x 105 93.9	20,000 41,992	
	Supra R17	 50 mL Round	-	29 x 100 98.9	15,000 24,878	
		 15 mL Round	TR15(50) 	17 x 94 92.8	15,000 23,344	
		 15 mL Conical	TR15c(50) 	17 x 105 93.9	15,000 23,621	
	A85-6  Hole angle : $\angle 25^\circ$ Max. Capacity : 6 x 85 mL Size (ø x H) : ø209.1 x 112 mm Max. height for tube fit : 115.4 mm Incl. a coupling bolt lid	Supra R30	 85 mL Round	-	38.3 x 95 97.6	25,000 68,198
			 50 mL Round	TR50(85) 	29 x 95 92.9	25,000 64,912
			 50 mL Conical	TR50c(85) 	29.5 x 100 93	25,000 64,984
 15 mL Round			TR15(85) 	17 x 94 89	25,000 62,189	
 15 mL Conical			TR15c(85) 	17 x 100 89.2	25,000 62,329	
Supra R22		 85 mL Round	-	38.3 x 95 97.6	20,000 43,647	
		 50 mL Round	TR50(85) 	29 x 95 92.9	20,000 41,545	
		 50 mL Conical	TR50c(85) 	29.5 x 100 93	20,000 41,590	
		 15 mL Round	TR15(85) 	17 x 94 89	20,000 39,800	
		 15 mL Conical	TR15c(85) 	17 x 100 89.2	20,000 39,890	
Supra R17		 85 mL Round	-	38.3 x 95 97.6	15,000 24,551	
		 50 mL Round	TR50(85) 	29 x 95 92.9	15,000 23,369	
		 50 mL Conical	TR50c(85) 	29.5 x 100 93	15,000 23,394	
		 15 mL Round	TR15(85) 	17 x 94 89	15,000 22,388	
		 15 mL Conical	TR15c(85) 	17 x 100 89.2	15,000 22,438	

* Radius : From the center of the rotor to the inner end of tube carrier.

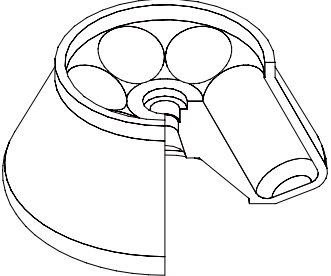
High Speed Centrifuges

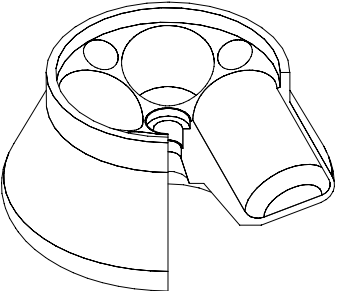
Supra R30 / Supra R22 / Supra R17 / Supra R12

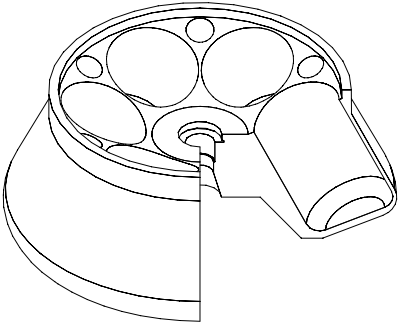
Fixed Angle Rotors for Supra Series (3)

Rotor	Adaptable Centrifuge	Tube Capacity Bottom Type	Bore Ø x L (mm) Radius (mm)	Max. RPM (rpm) Max. RCF (xg)
A250-6  Hole angle : $\angle 25^\circ$ Max. Capacity : 6 x 250 mL Size (Ø x H) : $\phi 295.6 \times 147.8$ mm Max. height for tube fit : 132 mm Incl. a coupling bolt lid	Supra R30	 250 mL Flat	62 x 103 138.3	10,000 15,462
	Supra R22			12,000 22,265
	Supra R17			10,000 15,462
	Supra R12			12,000 22,265
A500-6  Hole angle : $\angle 25^\circ$ Max. Capacity : 6 x 500 mL Size (Ø x H) : $\phi 336 \times 179$ mm Max. height for tube fit : 168.5 mm Incl. a coupling bolt lid	Supra R30	 500 mL Flat	70 x 141 158.7	8,000 11,355
	Supra R22			9,000 14,372
	Supra R12			10,000 17,743
A1000-4  Hole angle : $\angle 25^\circ$ Max. Capacity : 4 x 1,000 mL Size (Ø x H) : $\phi 350 \times 196$ mm Max. height for tube fit : 184.8 mm Incl. a coupling bolt lid	Supra R30	 1,000 mL Flat	98 x 144 169.9	7,000 9,307
	Supra R22			8,000 12,157
	Supra R12			
A1000-6  Hole angle : $\angle 25^\circ$ Max. Capacity : 6 x 1,000 mL Size (Ø x H) : $\phi 408 \times 188$ mm Max. height for tube fit : 176.5 mm Incl. a coupling bolt lid	Supra R12	 1,000 mL Flat	98 x 144 200.1	7,000 10,962

* Radius : From the center of the rotor to the inner end of tube carrier.

Multi-purpose Centrifuge

Combi R515

- Real multi-purpose centrifuge for using both fixed angle and swing-out rotors
- Robust and practical benchtop design
- For up to 15,000 rpm (24,000 xg) with 6 x 85 mL
- Large capacity swing-out rotor for 4 x 500 mL up to 4,500 rpm (4,300 xg)
- A variety of tube adaptors to be fit into 750 mL and 500 mL swing buckets
- Automatic rotor identification
- Imbalance cutoff and tracking
- Intuitive and easy control and extensively informative display
- Smoothly working, motorized lid opening and closure
- Cooled using CFC free, environmental friendly refrigerant
- Excellent temperature control
- Drainage from the chamber hole of refrigerated models could be cleaned daily
- Password lock function



S750-4 / B750 & TM96



S500-4 / B500 & TM96



A50-8



A0.2-48

Multi-purpose Centrifuges

Combi R515 / Combi 508

Multi-purpose Centrifuge

Combi 508

- Compact benchtop, multi-purpose centrifuge
- Ideal for routine usage of 4 x 750 mL swing-out centrifugation
- Very quiet and static operation with BLDC motor
- A variety of tube adaptors could be fitted into the 750 mL and 500 mL swing buckets
- Automatic rotor identification
- Imbalance cutoff and tracking
- Intuitive and easy control and extensive and informative display
- Smoothly working, motorized lid opening and closure



Unique air flow structure for effective noise reduction and excellent cooling









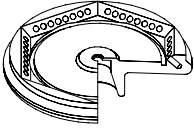
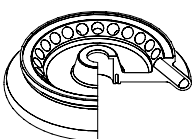

Technical Specifications

		Combi R515	Combi 508
Speed RCF (xg)	Max. RPM / Fixed angle	15,000 rpm	8,000 rpm
	Max. RCF / Fixed angle	26,664 xg	8,279 xg
	Max. RPM / Swing-out	4,500 rpm	4,000 rpm
	Max. RCF / Swing-out	4,392 xg	3,515 xg
Max. capacity	Fixed angle	6 x 250 mL, 36 x 1.5/2.0 mL	6 x 85 mL
	Swing-out	4 x 750 mL, 76 x 15 mL, 4 MTPs	4 x 750 mL
ACC/DEC ramps		10/10 steps	
Temperature range		-10°C to 40°C	-
Time control		< 100 hr, pulse, continuous	< 2 hr, continuous
Program memory		100	
Noise level		≤ 65 dB	≤ 65 dB
Imbalance cutoff / tracking		Yes / Yes	Yes / Yes
Rotor identification		Automatic	Automatic
Dimension (W x D x H, mm)		723 x 665 x 387	530 x 676 x 400
Weight without rotor		95 kg	61 kg
Power consumption		2.5 kw	2.1 kVA
Power input (V, Hz)		220V, 60HZ	
Cat. No.		CB-R515	CB-508

* Registered as medical device at MFDS¹⁾

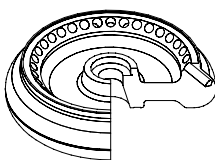
¹⁾ MFDS : Ministry of Food and Drug Safety (KOREA)

Fixed Angle Rotors for Combi Series (1)

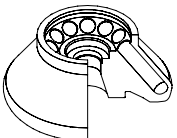
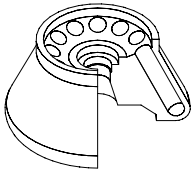
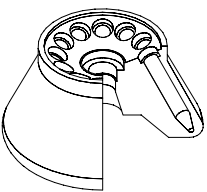









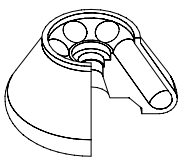









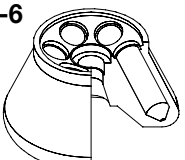

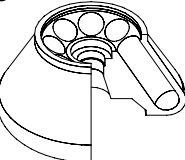









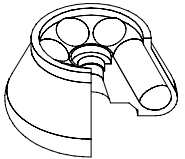









Rotor	Adaptable Centrifuge	Tube Capacity Bottom Type	Required Adaptor	Bore Ø x L (mm) Radius (mm)	Max. RPM (rpm) Max. RCF (xg)	
A0.2-48  Hole angle : $\angle 45^\circ$ Max. Capacity : 48 x 0.2 mL Size (ø x H) : ø200 x 56 mm Incl. a coupling bolt lid	Combi R515	0.2 mL -	-	6.5 x 17 88.9	12,500 15,530	
		0.2 mL PCR strip	-			
	Combi 508	0.2 mL -	-	6.5 x 17 88.9	8,000 6,361	
		0.2 mL PCR strip	-			
A2.0-24  Hole angle : $\angle 40^\circ$ Max. Capacity : 24 x 1.5/2.0 mL Size (ø x H) : ø202 x 79 mm Max. height for tube fit : 46 mm Incl. a coupling bolt lid	Combi R515	1.5/2.0 mL -	-	11.5 x 38 80.8	15,000 20,325	
		0.5 mL -	TR0.5		8 x 37 76.5	15,000 19,244
		0.2 mL -	TR0.2		6 x 21 67	15,000 16,854
	Combi508	1.5/2.0 mL -	-	-	11.5 x 38 80.8	8,000 5,781
		0.5 mL -	TR0.5		8 x 37 76.5	8,000 5,473
		0.2 mL -	TR0.2		6 x 21 67	8,000 4,795
A2.0-36  Type : Fixed Angle Rotor 30° Max. Capacity : 36 x 1.5/2.0 mL Size (ø x H) : ø240 x 64 mm Max. height for tube fit : 49 mm Incl. a coupling bolt lid	Combi R515	1.5/2.0 mL Micro-filter tube	-	11.5 x 38 115.7	14,000 25,353	
		0.5 mL -	TR0.5		8 x 37 111	14,000 24,323
		0.2 mL -	TR0.2		6 x 21 100	14,000 21,913
	Combi 508	1.5/2.0 mL Micro-filter tube	-	-	11.5 x 38 115.7	8,000 8,279
		0.5 mL -	TR0.5		8 x 37 111	8,000 7,942
		0.2 mL -	TR0.2		6 x 21 100	8,000 7,155
A10-12  Hole angle : $\angle 36^\circ$ Max. Capacity : 12 x 10 mL Size (ø x H) : ø179.9 x 82 mm Max. height for tube fit : 87.1 mm Incl. a coupling bolt lid	Combi R515	10 mL Round	-	16.3 x 74.5 85.1	15,000 21,407	
	Combi 508		8,000 6,089			
A15-12  Hole angle : $\angle 30^\circ$ Max. Capacity : 12 x 15 mL Size (ø x H) : ø222.7 x 106 mm Max. height for tube fit : 121 mm Incl. a coupling bolt lid	Combi R515	15(16) mL Round	-	17 x 96 106	15,000 26,664	
	Combi 508		8,000 7,585			
A15c-12  Hole angle : $\angle 25^\circ$ Max. Capacity : 12 x 15 mL conical Size (ø x H) : ø215 x 121 mm Max. height for tube fit : 123.2 mm Incl. a coupling bolt lid	Combi R515	15 mL Conical	-	17 X 115 99.4	15,000 25,004	
	Combi 508		8,000 7,105			

* Radius : From the center of the rotor to the inner end of tube carrier.

Multi-purpose Centrifuges

Combi R515 / Combi 508

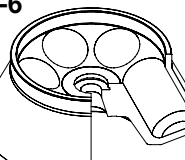
Fixed Angle Rotors for Combi Series (2)

Rotor	Adaptable Centrifuge	Tube Capacity Bottom Type	Required Adaptor	Bore Ø x L (mm) Radius (mm)	Max. RPM (rpm) Max. RCF (xg)
A50-6  Hole angle : $\angle 30^\circ$ Max. Capacity : 6 x 50 mL Size (ø x H) : ø200 x 109 mm Max. height for tube fit : 122.7 mm Incl. a coupling bolt lid	Combi R515	 50 mL Round	-	29 x 100 96.1	15,000 24,174
		 15 mL Round	TR15(50) 	17 x 94 89.9	15,000 22,614
		 15 mL Conical	TR15c(50) 	17 x 105 91	15,000 22,891
	Combi 508	 50 mL Round	-	29 x 100 96.1	8,000 6,876
		 15 mL Round	TR15(50) 	17 x 94 89.9	8,000 6,433
		 15 mL Conical	TR15c(50) 	17 x 105 91	8,000 6,511
A50c-6  Hole angle : $\angle 23^\circ$ Max. Capacity : 6 x 50 mL conical Size (ø x H) : ø205.7 x 119 mm Max. height for tube fit : 118.1 mm Incl. a coupling bolt lid	Combi R515	 50 mL Conical	-	30 x 108.6 91	15,000 22,891
	Combi 508		8,000 6,511		
A50-8  Hole angle : $\angle 30^\circ$ Max. Capacity : 8 x 50 mL Size (ø x H) : ø213 x 110.7 mm Max. height for tube fit : 110.7 mm Incl. a coupling bolt lid	Combi R515	 50 mL Round	-	29 x 100 98.9	15,000 24,878
		 15 mL Round	TR15(50) 	17 x 94 92.8	15,000 23,344
		 15 mL Conical	TR15c(50) 	17 x 105 93.9	15,000 23,621
	Combi 508	 50 mL Round	-	29 x 100 98.9	8,000 7,077
		 15 mL Round	TR15(50) 	17 x 94 92.8	8,000 6,640
		 15 mL Conical	TR15c(50) 	17 x 105 93.9	8,000 6,719
A85-6  Hole angle : $\angle 25^\circ$ Max. Capacity : 6 x 85 mL Size (ø x H) : ø209.1 x 112 mm Max. height for tube fit : 115.4 mm Incl. a coupling bolt lid	Combi R515	 85 mL Round	-	38.3 x 95 97.6	15,000 24,551
		 50 mL Round	TR50(85) 	29 x 95 92.9	15,000 23,369
		 50 mL Conical	TR50c(85) 	29.5 x 100 93	15,000 23,394
		 15 mL Round	TR15(85) 	17 x 94 89	15,000 22,388
		 15 mL Conical	TR15c(85) 	17 x 100 89.2	15,000 22,438
	Combi 508	 85 mL Round	-	38.3 x 95 97.6	8,000 6,983
		 50 mL Round	TR50(85) 	29 x 95 92.9	8,000 6,647
		 50 mL Conical	TR50c(85) 	29.5 x 100 93	8,000 6,654
		 15 mL Round	TR15(85) 	17 x 94 89	8,000 6,368
		 15 mL Conical	TR15c(85) 	17 x 100 89.2	8,000 6,382
A250-6  Hole angle : $\angle 25^\circ$ Max. Capacity : 6 x 250 mL Size (ø x H) : ø295.6 x 147.8 mm Max. height for tube fit : 132 mm Incl. a coupling bolt lid	Combi R515	 250 mL Round	-	62 x 103 138.3	8,000 9,896

* Radius : From the center of the rotor to the inner end of tube carrier.

Swing-out Rotors for Combi Series

S750-4

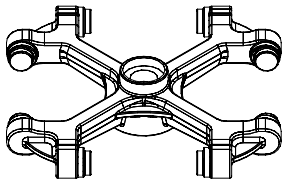

∠90°
 Max. RPM : 4,000 rpm
 Size (W x D x H)
 : 277 x 277 x 55 mm

Bucket/Adaptor for S750-4



Round Bucket
B750S
 Capacity : 750 mL

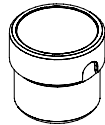

Round Bucket
B750
 Capacity : 750 mL

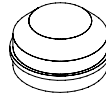

Cap
BL750

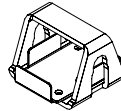

MicroTiter Plate Rack
TM96 (750-4)

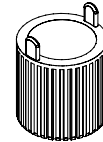

Adaptor
TR500 (750)



Adaptor
TR500c (750)

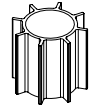

Adaptor
TR250 (750)

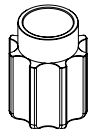

Adaptor
TR250c (750)

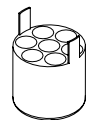

Adaptor
TR50-7

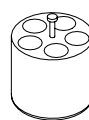

Adaptor
TR50c-5

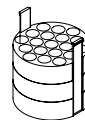

Adaptor
TR15-19

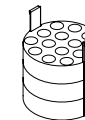

Adaptor
TR15c-14

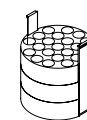



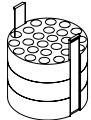





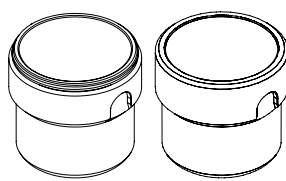
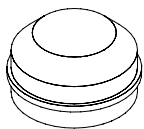















Adaptor
TR10-21

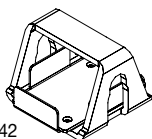

Adaptor
TR5-24

Buckets and Tube Racks of S750-4

Bucket	Required Adaptor	Tube Capacity Bottom Type	Tube per Adaptor / Rotor	Bore (Ø x L, mm)	Max. height for tube fit (mm)		Max. RPM (rpm) Max. RCF (xg)
					w/ cap	w/o cap	
B750S / B750  BL750  Radius : 196.5 mm Bucket bore (ø x L, mm) : 99 x 103 Max. height for tube fit : 142 mm (w/ cap), 157.5 mm (w/o cap)	-	 750 mL Flat	1 / 4	99 x 103	142	158.5	4,000 3,515
	TR500(750) 	 500 mL Flat	1 / 4	75.5 x 98.7	138.2	150.6	4,000 3,458
	TR500c(750) 	 500 mL Conical	1 / 4	99 x 58	140.2	152.5	4,000 3,515
	TR250(750) 	 250 mL Flat	1 / 4	62.3 x 87	137.5	146.7	4,000 3,443
	TR250c(750) 	 250 mL Conical	1 / 4	60.5 x 124.4	138	148.1	4,000 3,452
	TR50-7 	 50 mL Round	7 / 28	29.2 x 97	129.1	135.3	4,000 3,443
	TR50c-5 	 50 mL Conical	5 / 20	29 x 91	125.1	131.2	4,000 3,515
	TR15-19 	 15 mL Round	19 / 76	17.2 x 87	123.7	129.8	4,000 3,443
	TR15c-14 	 15 mL Conical	14 / 56	17 x 89	125.5	131.6	4,000 3,479
	TR10-21 	 10 mL Round	21 / 84	16 x 87	123.9	130	4,000 3,443
	TR5-24 	 3 mL / 5 mL Round	24 / 96	13.2 x 60 (3 mL) 13.2 x 87 (5 mL)	123.2	129.3	4,000 3,443
TM96(750-4) Radius : 163.5 mm MTP holder size (w x d x L, mm) : 88 x 128.5 x 42 Max. height for tube fit : 88 x 128.5 x 42 mm		 MTP	1 / 4	88 x 128.5 x 42			129.3

* Radius : From the center of the rotor to the inner end of tube carrier.

Multi-purpose Centrifuges

Combi R515 / Combi 508

S500-4

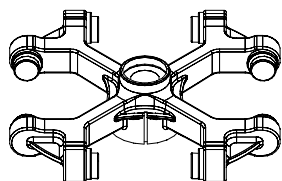

∠90°
 Max. RPM : 4,500
 Size (W x D x H)
 : 262 x 262 x 55 mm

Bucket/Adaptor for S500-4

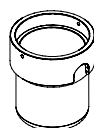

Round Bucket
B500
 Capacity : 500 mL
 * Cap included



Cap
BL500

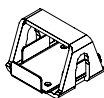

MicroTiter Plate Rack
TM96
(500-4)



Adaptor
TR500
(500)



Adaptor
TR250
(500)

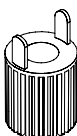

Adaptor
TR100
(500)

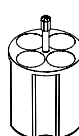

Adaptor
TR50-4

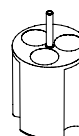

Adaptor
TR50c-3

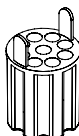

Adaptor
TR15-9

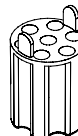

Adaptor
TR15c-7

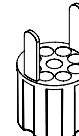



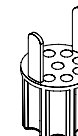





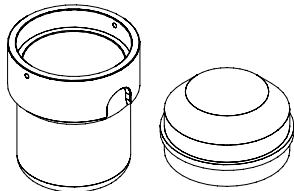











Adaptor
TR10-9

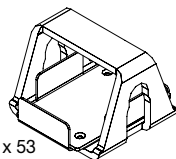

Adaptor
TR5-9

Buckets and Tube Racks of S500-4

Bucket	Required Adaptor	Tube Capacity Bottom Type	Tube per Adaptor / Rotor	Bore (Ø x L, mm)	Max. height for tube fit (mm)		Max. RPM (rpm) Max. RCF (xg)
					w/ cap	w/o cap	
 Radius : 194 mm Bucket bore (ø x L, mm) : 80 x 111 Max. height for tube fit : 143.5 mm (w/ cap), 157.2 mm (w/o cap) Incl. a cap Combi R515 Max. RPM : 4,500 Max. RCF : 4,392 xg Combi 508 Max. RPM : 4,000 Max. RCF : 3,435 xg	TR500(500) 	 500 mL Flat	1 / 4	73 x 125	141.5	143.6	4,500 4,347
	TR250(500) 	 250 mL Flat	1 / 4	62 x 100	135	146.6	4,500 4,290
	TR100(500) 	 100 mL (85 mL) Round	1 / 4	38.5 x 84.5	139	150.9	4,500 4,290
	TR50-4 	 50 mL Round	4 / 16	29.5 x 85.5	129	140.6	4,500 4,290
	TR50c-3 	 50 mL Conical	3 / 12	30 x 90	128.3	140	4,500 4,302
	TR15-9 	 15 mL Round	9 / 36	16.5 x 85	132.1	146.8	4,500 4,290
	TR15c-7 	 15 mL Conical	7 / 28	17 x 95.5	128.4	140.1	4,500 4,313
	TR10-9 	 10 mL Round	9 / 36	17 x 64	132.9	144.6	4,500 4,279
	TR5-9 	 5 mL Round	9 / 36	13 x 64	133.8	145.5	4,500 4,256
TM96(500-4) Radius : 154 mm MTP holder size (w x d x L, mm) : 87 x 128.5 x 53 Max. height for tube fit : 87 x 128.5 x 53 mm		 MTP	1 / 4	-	87 x 128.5 x 53		145.5

* Radius : From the center of the rotor to the inner end of tube carrier.

Large Capacity Centrifuges

Component R12 / R6 / wR

- Well recognized model in blood banks and large sample handling laboratories
- Optimized for consistent separation of plasma, buffy coat, RBC, etc.
- Any types of blood bags applicable from 250 mL to 500 mL
- 12 blood bags per run (Component R12), 6 blood bags per run (Component R6)
- Ideal for large number of sample handling (180 vacutainers at a time)
- Windshield rotor to reduce the air resistance and enable to spin over 4,000 rpm
- Dual ramp acceleration and deceleration profile for gentle and quick running
- Ergonomically arranged control and large display with comprehensive information
- Imbalance cutoff and tracking
- Excellent temperature control
- Easy to clean specially coated glossy surface



WS1000-6 / B1000

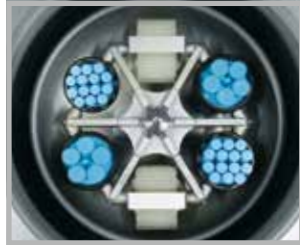

WS750-6 / B750 & TM96

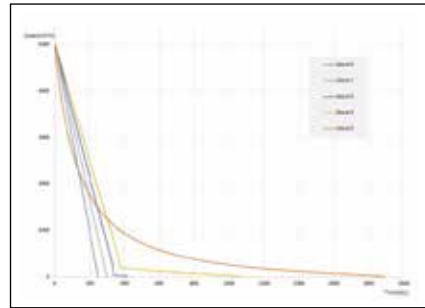

Two-step DEC control at DEC 1~5 and natural slow break at DEC 0



Component R6



Component R12

Large Capacity Centrifuges

Component R12 / Component R6 / Component wR



Component wR

Technical Specifications

		Component R12	Component R6	Component wR
Speed	Max. RPM / Swing-out	4,500 rpm	5,000 rpm	4,500 rpm
RCF (xg)	Max. RCF / Swing-out	6,491 xg	7,261 xg	5,096 xg
Max. capacity / Swing-out		6 x 2,400 mL	6 x 1,000 mL	6 x 750 mL
ACC/DEC	ACC/DEC ramps	10/10 steps		
	Two step Deceleration	Yes		
Temperature	Temperature range	-10°C to 40°C	-20°C to 40°C	-20°C to 40°C
	Temperature offset	Yes		
Time control		< 100 hr, continuous	< 100 hr, continuous	< 100 hr, pulse, continuous
Program memory		100		
Noise level		≤ 65 dB	≤ 65 dB	≤ 65 dB
Imbalance cutoff / tracking		Yes / Yes	Yes / Yes	Yes / Yes
Rotor identification		Automatic		
Dimension (W x D x H, mm)		840 x 980 x 970	816 x 906 x 965	668.7 x 800.6 x 891.3
Weight without rotor		480 kg	380 kg	250 kg
Power consumption		3.0 kVA	6.3 kVA	5.0 kVA
Power input (V, Hz)		210~240V, 60 Hz (110V, 50 Hz optional)		210~240 V, 50/60 Hz (110V optional)
Cat. No.		CP-R12	CP-R6	CP-wR

* Registered as medical device at MFDS¹⁾

¹⁾ MFDS : Ministry of Food and Drug Safety (KOREA)

Swing-out Rotor for Component R12

WS2400-6

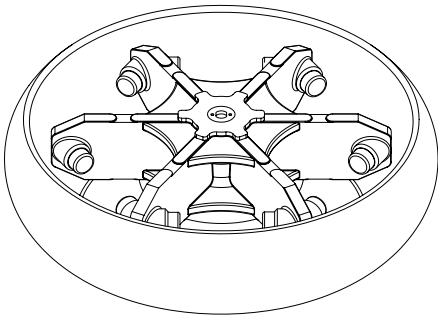

∠90°
Max. RPM : 4,800 rpm
Dim. W x D x H : 494 x 435.6 x 125 mm (w/o windshield)
Incl. a windshield and a lid

Bucket/Adaptor for WS2400-6

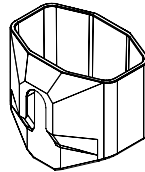

Blood Bag Bucket
B2400

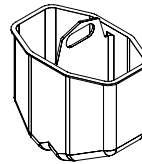

Adaptor
TRB500-2

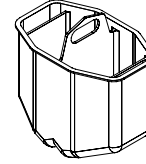

Adaptor
TRB450-2

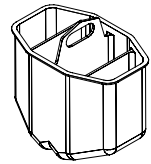

Adaptor
TRB250-2

Bucket and Tube Racks of WS2400-6

Bucket	Required Adaptor	Tube Capacity	Tube per Adaptor / Rotor	Max. height for tube fit (mm)	Max. RPM (rpm) Max. RCF (xg)
 Radius : 286.7 mm Bucket bore (ø x L, mm) : 176.9 x 150.8 Max. height for tube fit: 209.2 mm	TRB500-2 	500 mL	2 / 12	209.2	4,500 6,491
	TRB450-2 	450 mL	2 / 12		
	TRB250-2 	250 mL	2 / 12		

* Radius : From the center of the rotor to the inner end of tube carrier.

Large Capacity Centrifuges

Component R12 / Component R6 / Component wR

Swing-out Rotor for Component R6

WS1000-6

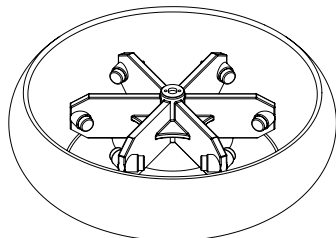

∠90°

Max. RPM : 5,000 rpm

Dim. W x D x H : 384 x 340 x 99 mm (w/o windshield)

Incl. a windshield and a lid

Bucket/Adaptor for WS1000-6

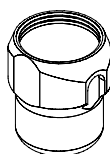

Bucket
B1000S

Capacity : 1,000 mL
* Cap Available (optional)

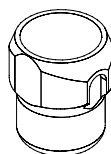

Bucket
B1000

Capacity : 1,000 mL





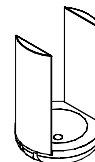

Cap
BL1000

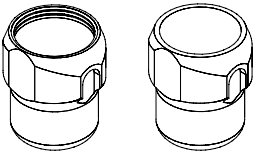

Adaptor
TRB450

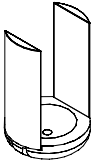
Bucket and Tube Racks of WS1000-6

Bucket	Required Adaptor	Tube Capacity Bottom Type	Tube per Adaptor / Rotor	Bore (Ø x L, mm)	Max. height for tube fit (mm)		Max. RPM (rpm) Max. RCF (xg)
					w/ cap	w/o cap	
B1000S / B1000 	-	 1,000 Flat	1 / 6	98.5 X 143	169.5	182.2	5,000 7,261
BL1000  Radius : 259.8 mm Bucket bore (Ø x L, mm) : 98.5 x 143 Max. height for tube fit : 169.5 mm (w/ cap), 182.2 mm (w/o cap)	TRB450 	 450 mL -	1 / 6	65.5 x 135	178.7		5,000 6,842

* Radius : From the center of the rotor to the inner end of tube carrier.

Swing-out Rotor for Component wR

WS750-6

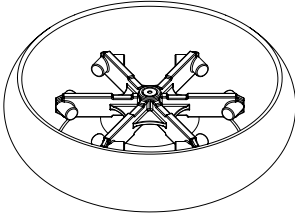

∠90°

Max. RPM : 4,500 rpm

Size (ø x H) : Ø262 x 262 mm
(w/o windshield)

Incl. a windshield and a lid

Bucket/Adaptor for WS750-6



Round Bucket
B750S

Capacity : 750 mL
* Cap Available (optional)



Round Bucket
B750

Capacity : 750 mL

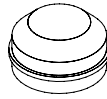

Cap
BL750

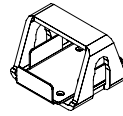

MicroTiter Plate Rack
TM96 (750-4)

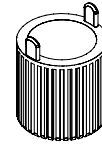

Adaptor
TR500 (750)



Adaptor
TR500c (750)

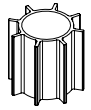

Adaptor
TR250 (750)

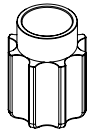

Adaptor
TR250c (750)

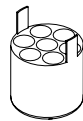

Adaptor
TR50-7

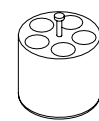

Adaptor
TR50c-5

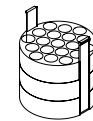

Adaptor
TR15-19

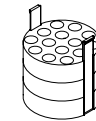

Adaptor
TR15c-14

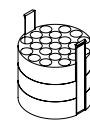



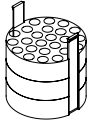





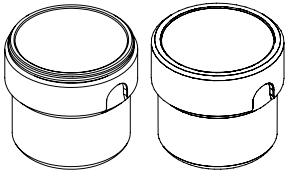
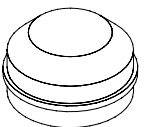















Adaptor
TR10-21

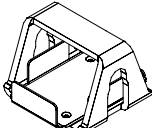

Adaptor
TR5-24

Bucket and Tube Racks of WS750-6

Bucket	Required Adaptor	Tube Capacity Bottom Type	Tube per Adaptor / Rotor	Bore (Ø x L, mm)	Max. height for tube fit (mm)		Max. RPM (rpm) Max. RCF (xg)
					w/ cap	w/o cap	
B750S / B750  BL750 	-	 750 mL Flat	1 / 6	99 x 103	129	161.5	4,500 5,096
	 TR500(750)	 500 mL Flat	1 / 6	75.5 x 98.7	125.2	129	4,500 5,042
	 TR500c(750)	 500 mL conical Conical	1 / 6	99 x 58	126.7	154.3	4,500 5,096
	 TR250(750)	 250 mL Flat	1 / 6	62.3 x 87	124.5	149	4,500 5,003
	 TR250c(750)	 250 mL conical Conical	1 / 6	60.5 x 124.4	125	150	4,500 5,015
	 TR50-7	 50 mL Round	7 / 42	29.2 x 97	124	131.8	4,500 5,003
	 TR50c-5	 50 mL conical Conical	5 / 30	29 x 91	116.2	125.5	4,500 5,096
	 TR15-19	 15 mL Round	19 / 114	17.2 x 87	114.6	122.4	4,500 5,003
	 TR15c-14	 15 mL conical Conical	14 / 84	17 x 89	117	124.8	4,500 5,049
	 TR10-21	 10 mL Round	21 / 126	16 x 87	113.9	121.7	4,500 5,003
	 TR5-24	 3 mL / 5 mL Round	24 / 144	13.2 x 60 (3 mL) 13.2 x 87 (5 mL)	113.7	121.5	4,500 5,003
	TM96(750-6) Radius : 191.9 mm MTP holder size (w x d x L, mm) : 88 x 128.5 x 42 Max. height for tube fit : 88 x 128.5 x 42 mm		 MTP	1 / 6	88 x 128.5 x 42		

* Radius : From the center of the rotor to the inner end of tube carrier.

Clinical Centrifuge

Fleta 4

- Multi-purpose, small benchtop centrifuge generally for routine clinical work
- Fixed angle rotor (up to 24 tubes per run) for chemical analysis of urine, blood and biological samples
- Well noted for stable separation of blood with swing-out buckets for syringe type
- Two-steps deceleration to maintain finely separated sample
- Rapid acceleration and deceleration (20/20 sec)
- Easy to read graphic LCD display
- Surface anodized aluminum chamber
- Compact and light-weighted design
- Easy to clean specially coated glossy surface

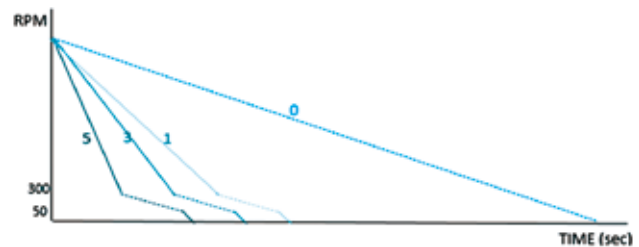

Deceleration profile



S85-4



S50-6







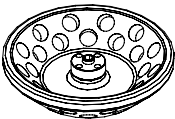

Technical Specifications

		Fleta 4
Speed RCF (xg)	Max. RPM / Fixed angle	4,000 rpm
	Max. RCF / Fixed angle	2,635 xg
	Max. RPM / Swing-out	4,000 rpm
	Max. RCF / Swing-out	3,243 xg
Capacity	Max. capacity / Fixed angle	24 x 15 mL
	Max. capacity / Swing-out	6 x 50 mL, 12 x 15 mL conical, 4 x 85 mL
ACC/DEC	ACC/DEC ramps	5/6 steps
	Two step Deceleration	Yes
	Acc. time to max. speed	35/110 sec
	Dec. time from max. speed	38/110 sec
Time control		< 100 min, pulse, continuous
Program memory		10
Noise level		< 60 dB
Imbalance cutoff		Yes
Rotor identification		manual
Dimension (W x D x H, mm)		448.5 x 531 x 286
Weight without rotor		25 kg
Power consumption		620 VA
Power input (V, Hz)		210~240 V, 50/60 Hz (110V optional)
Cat. No.		FL-4

* Registered as medical device at MFDS¹⁾

¹⁾ MFDS : Ministry of Food and Drug Safety (KOREA)

Fixed Angle Rotors for Fleta 4

Rotor	Tube Capacity Bottom Type	Required Sleeve (Bore)	Required Adaptor for Blood tube	Bore Ø x L (mm) Radius (mm)	Max. RPM (rpm) Max. RCF (xg)
AL15-24  Hole angle : $\angle 45^\circ$ Max. Capacity : 24 x 15 mL Size (ø x H) : 197 x Max. height for tube fit : 143.3 mm	15 mL Round/Conical ø13, ø16 Blood tube	 TR15(15) 18 x 94.5	 TR3(15)	13.5 x 61 147.3	4,000 2,635
			 TR5(15)	13.5 x 85 147.3	
AL15-12  Hole angle : $\angle 45^\circ$ Max. Capacity : 12 x 15 mL Dim. ø x H : 164.6 x 42.8 mm Max. height for tube fit : 134 mm	15 mL Round/Conical ø13, ø16 Blood tube	 TR15(15) 18 x 94.5	 TR3(15)	13.5 x 61 133.9	4,000 2,395
			 TR5(15)	13.5 x 85 133.9	

* Radius : From the center of the rotor to the inner end of tube carrier.

Swing-out Rotors for Fleta 4

S85-4

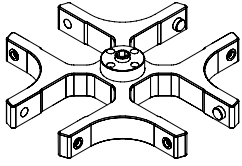





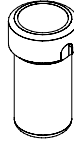



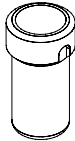

∠90°
 Max. RPM : 4,000 rpm
 Size (ø x H) : Ø230 x 36 mm

Bucket for S85-4



Bucket
B85

Buckets and Adaptors of S85-4

Bucket	Required Adaptor	Tube Capacity Bottom Type	Tube per Adaptor / Rotor	Bore (Ø x L, mm)	Max. height for tube fit (mm)	Max. RPM (rpm) Max. RCF (xg)
 Radius(mm): 172.6 Bucket bore (ø x L, mm) : 38.5 x 88.5 Max. height for tube fit (mm) : 142.5	-	 85 mL Round	1 / 4	38.5 x 88.5	142.5	4,000 3,087
	TR50(85) 	 50 mL Round	1 / 4	29 x 95	142.8	4,000 3,001
	TR50c(85) 	 50 mL Conical	1 / 4	29.5 x 100	142.7	4,000 3,087
	TR15(85) 	 15 mL Round	1 / 4	17 x 94	142.8	4,000 2,984
	TR15c(85) 	 15 mL Conical	1 / 4	17 x 100	146.8	4,000 3,087

* Radius : From the center of the rotor to the inner end of tube carrier.

S50-6

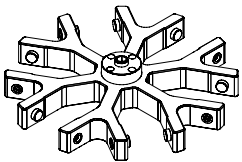

∠90°
 Max. RPM : 4,000 rpm

Bucket for S50-6

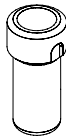



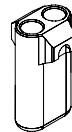





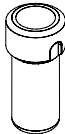

Bucket
B50

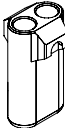

Bucket
B15c-2

Buckets and Adaptors of S50-6

Bucket	Required Adaptor	Tube Capacity Bottom Type	Tube per Adaptor / Rotor	Bore (Ø x L, mm)	Max. height for tube fit (mm)	Max. RPM (rpm) Max. RCF (xg)
 Radius : 181.3 mm Bucket bore (ø x L, mm) : 30.3 x 93.5 Max. height for tube fit (mm) : 145.7	-	 50 mL Round	1 / 6	30 x 93.5	145.7	4,000 3,243
	TR50c(50) 	 50 mL Conical	1 / 6		126.5	
	TR25(50) 	 25 mL Round	1 / 6	20 x 87	137.2	
	TR15(50) 	 15(16) mL Round	1 / 6	18 x 87	141.5	
 Radius : 165.8 mm		 15 mL Conical	2 / 12	17 x 86.5	138.7	4,000 2,966

* Radius : From the center of the rotor to the inner end of tube carrier.

Clinical Centrifuge

Fleta 5

- Benchtop centrifuge for performing daily routine tasks in hospital, university, and laboratory
- Optimized swing-out separation up to 5,500 rpm (6,200 xg)
- Maximized flexibility with large assorted accessories for using tubes from micro to 50 mL
- Simple knob control for speed and time
- Rapid acceleration and deceleration (20/20 sec)
- Very quiet and static operation with BLDC motor
- Lid drop protected construction and fine control of lid opening
- Surface anodized aluminum chamber
- Robust design for daily use

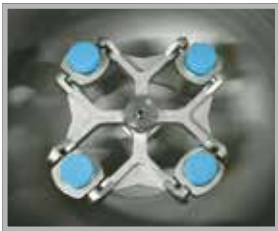

HSR-4S / HTB50c-4



HSM-2

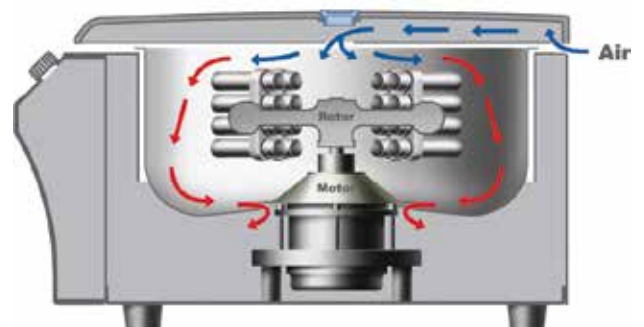

Unique air flow structure for effective noise reduction and excellent cooling

Technical Specifications

		Fleta 5
Speed RCF (xg)	Max. RPM / Fixed angle	-
	Max. RCF / Fixed angle	-
	Max. RPM / Swing-out	5,500 rpm
	Max. RCF / Swing-out	6,230 xg
Capacity	Max. capacity / Fixed angle	-
	Max. capacity / Swing-out	32 x 15 mL
ACC/DEC	ACC/DEC ramps	9/10 steps
	Two step Deceleration	-
	Acc. time to max. speed	20/80 sec
	Dec. time from max. speed	26/82 sec
Time control		< 100 hr, continuous
Program memory		100
Noise level		≤ 65 dB
Imbalance cutoff		Yes
Rotor identification		manual
Dimension (W x D x H, mm)		570 x 475 x 325
Weight without rotor		37 kg
Power consumption		1.0 kVA
Power input (V, Hz)		210~240 V, 50/60 Hz (110V optional)
Cat. No.		FL-5

* Registered as medical device at MFDS¹⁾

¹⁾ MFDS : Ministry of Food and Drug Safety (KOREA)

Swing-out Rotors for Fleta 5

HSR-4S

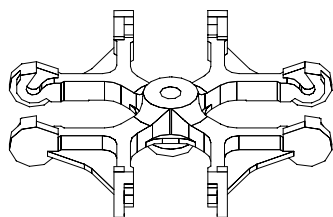

∠90°

Max. RPM : 5,500 rpm

Size (ø x H) : Ø235.8 x 42 mm

Bucket/Adaptor for HSR-4S

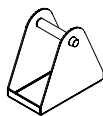

Rack Holder
HBTM

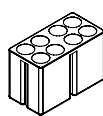

Adaptor
TR15-8

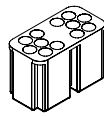

Adaptor
TR10-12

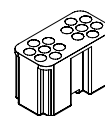

Adaptor
TR5-14

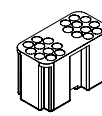

Adaptor
TR3-20

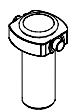

Bucket
HBT50-1

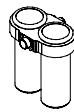

Bucket
HBT50-2

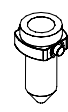

Bucket
HBT50c-1

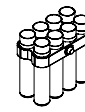



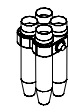







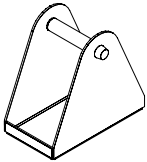







Bucket
HBT15-8



Bucket
HBT15c-4

* TR series adaptors described above are used in HBTM bucket.

Buckets and Adaptors of HSR-4S

Bucket	Required Adaptor	Tube Capacity Bottom Type	Tube per Adaptor / Rotor	Bore (Ø x L, mm)	Max. height for tube fit (mm)	Max. RPM (rpm) Max. RCF (xg)
HBTM  Radius : 164.1 mm MTP holder size (w x d x L, mm) : 90.3 x 47.2 x 57.2 Max. height for tube fit : 67.5 mm	TR15-8 	 15(16) mL Round	8 / 32	18 x 55	132.9	3,000 1,651
	TR10-12 	 10 mL Round	12 / 48	13 x 55	132.9	3,000 1,651
	TR5-14 	 5 mL Round	14 / 56	11 x 55	132.9	3,000 1,651
	TR3-20 	 3 mL Round	20 / 80	10 x 55	131.2	3,000 1,651
HBT50-1 Radius : 181.3 mm Bucket bore (ø/H, mm) : 30 x 99 Max. height for tube fit : 153.2 mm		 50 mL Round	1 / 4	30 x 99	154.3	5,500 6,131
HBT50-2 Radius : 181.3 mm Bucket bore (ø/H, mm) : 30 x 99 Max. height for tube fit : 153.2 mm		 50 mL Round	2 / 8	30 x 99	154.3	4,500 4,104
HBT50c-1 Radius : 184.2 mm Bucket bore (ø/H, mm) : 31.5 x 116 Max. height for tube fit : 144 mm		 50 mL Conical	1 / 4	31.5 x 115.9	143.4	5,500 6,230
HBT15-8 Radius : 162.7 mm Bucket bore (ø/H, mm) : 18 x 89.5 Max. height for tube fit : 125.3 mm		 15(16) mL Round	8 / 32	18 x 89.5	138.2	4,000 2,910
HBT15c-4 Radius : 172.7 mm Bucket bore (ø/H, mm) : 18 x 99.5 Max. height for tube fit : 143 mm		 15 mL Conical	4 / 16	18 x 99.5	147.6	4,000 3,089

* Radius : From the center of the rotor to the inner end of tube carrier.

HSM-2

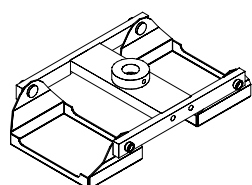

$\angle 90^\circ$
 Max. RPM : 2,000 rpm
 MTP holder size (W x D x H) : 174 x 212 x 20 mm
 Radius : 139 mm
 Max. height for tube fit : 127.3 x 88 x 110 mm

Tube Capacity	Tube per Adaptor / Rotor	Max. RPM (rpm) Max. RCF (xg)
MTP	1 / 2	2,000 622
Cell Culture		
DWP		

Clinical Centrifuge

HematoSpin II

- Micro hematocrit centrifuge
- Perfect for hematology and buffy coat analysis
- Easy reading and calculation through the graduated bottom rotor
- Easy to use snap-fit lid lock of hematocrit rotor
- Easy to read graphical LCD display
- Smoothly working, motorized lid opening and closure
- Compact, light-weighted, and ergonomic design
- Unique air-flow structure
- Easy to clean specially coated glossy surface



Technical Specifications

		HematoSpin II
Speed RCF (xg)	Max. RPM / Fixed angle	12,000 rpm
	Max. RCF / Fixed angle	15,536 xg
Max. capacity / Fixed angle		24 x 0.07 mL capillary
ACC/DEC	ACC/DEC ramps	5 / 6 steps
	Acc. time to max. speed	35 / 59 sec
	Dec. time from max. speed	60 / 85 sec
Time control		< 100 min, pulse, continuous
Program memory		10
Noise level		< 60 dB
Imbalance cutoff		Yes
Dimension (W x D x H, mm)		293 x 380 x 242
Weight without rotor		15 kg
Power consumption		714 VA
Power input (V, Hz)		210–240V, 50/60 Hz (110V optional)
Cat. No.		HE-II

Hematocrit Rotor for HematoSpin II

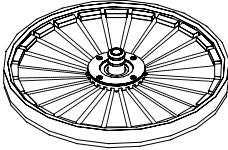
Rotor	Tube Capacity	Radius (mm)	Max. RPM (rpm) Max. RCF (xg)
<p>A-hemo-24</p>  <p>Consists of lid, scale plate, and tube insert plate A capillary is not included.</p>	24 x 0.07 mL capillary	96.5	12,000 15,536



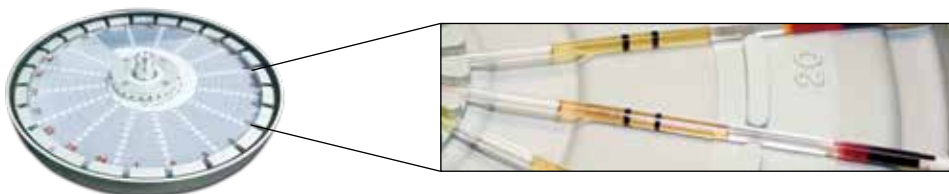











* Radius : From the center of the rotor to the inner end of tube carrier.

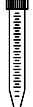



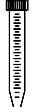





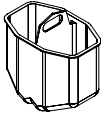
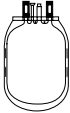
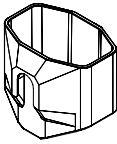
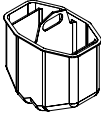
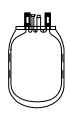
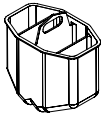

Accessories

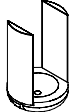
Tube Racks (Adaptors)

Adaptors of Fixed Angle Rotor

Adaptor	Bottom Type	Bore Ø x L (mm)	Compatible Tubes and Capacity	Compatible Rotors	Compatible Centrifuges
 TR 0.2 0.2 mL tube adaptor	Flat	6 x 21	 0.2 mL	A2.0-36 A2.0-24 A2.0M(MP)-24 A2.0M-18 A2.0-12	Smart R17 plus Smart 15 Plus Smart 13 Supra R30 Supra R22 Supra R17 Combi 508 Combi R515
 TR 0.5 0.5 mL tube adaptor	Flat	8 x 37	 0.5 mL		
 TR15(50) 15 mL tube adaptor to 50 mL hole	Round	17 x 94	 15 mL	A50-8 A50-6	Supra R30 Supra R22 Supra R17 Combi R515 Combi 508
 TR15c(50) 15 mL conical tube adaptor to 50 mL hole	Conical	17 x 105	 15 mL conical		
 TR15(85) 15 mL tube adaptor to 85 mL hole	Round	29 x 95	 15 mL	A85-6	
 TR15c(85) 15 mL conical tube adaptor to 85 mL hole	Conical	29.5 x 100	 15 mL conical		
 TR50(85) 50 mL tube adaptor to 85 mL hole	Round	17 x 94	 50 mL		
 TR50c(85) 50 mL conical tube adaptor to 85 mL hole	Conical	17 x 100	 50 mL conical		

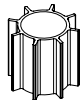
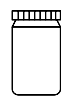
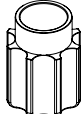
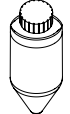
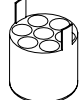
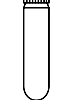
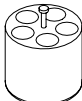
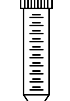
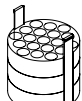
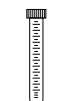
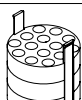

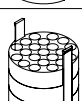
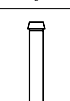
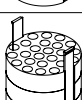
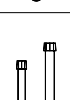



Adaptors of Swing-out Rotor

Adaptor	Bore Ø x L (mm)	Compatible Tubes and Capacity	Compatible Buckets	Compatible Rotors	Compatible Centrifuges
 TRB500-2 Adaptor for 500 mL blood bag	-	 2 x 500 mL blood bags	 B2400 Blood Bag Bucket	WS2400-6	Component R12
 TRB450-2 Adaptor for 450 mL blood bag	-	 2 x 450 mL blood bags			
 TRB250-2 Adaptor for 250 mL blood bag	-	 2 x 250 mL blood bags			
 Blood Bag Adaptor for 480 mL blood bag	65.5 x 135	 450 mL blood bags	B1000 B1000S	WS1000-6	Component R6
 TR500(750) 500 mL tube adaptor to 750 mL bucket	74 x 80	 500 mL	 B750S *cap available 750 mL Bucket B750 750 mL Bucket	WS750-6 S750-4	Combi R515 Combi 508 Component wR
 TR500c(750) 500 mL conical tube adaptor to 750 mL bucket	99 x 58	 500 mL			
 TR250(750) 250 mL tube adaptor to 750 mL bucket	62.3 x 87	 250 mL			
 TR250c(750) 250 mL conical tube adaptor to 750 mL bucket	60.5 x 124.4	 250 mL conical			
 TR50-7 50 mL tube adaptor to 750 mL bucket	29.2 x 97	 7 x 50 mL			
 TR50c-5 50 mL conical tube adaptor to 750 mL bucket	29 x 91	 5 x 50 mL conical			
 TR15-19 15 mL tube adaptor to 750 mL bucket	17.2 x 87	 19 x 15 mL			
 TR15c-14 15 mL conical tube adaptor to 750 mL bucket	17 x 89	 14 x 15 mL conical			
 TR10-21 10 mL tube adaptor to 750 mL bucket	16 x 87	 21 x 10 mL			
 TR5-24 3 or 5 mL tube adaptor to 750 mL bucket	5 mL : 13.2 x 87 3 mL : 13.2 x 60	 24 x 3 mL 24 x 5 mL			

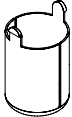

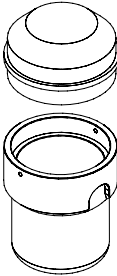
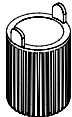
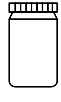
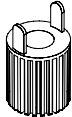
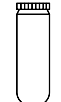
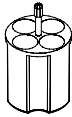
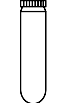
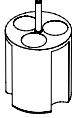
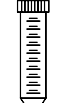

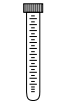
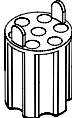
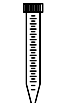
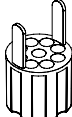
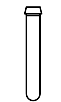
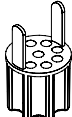









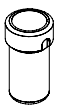

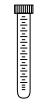



Accessories

Tube Racks (Adaptors)

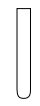
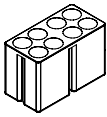
Adaptors of Swing-out Rotor

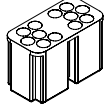
Adaptor	Bore Ø x L (mm)	Compatible Tubes and Capacity	Compatible Buckets	Compatible Rotors	Compatible Centrifuges
 <p>TR500(500) 500 mL tube adaptor to 500 mL bucket</p>	74 x 80	 <p>500 mL</p>	 <p>B500 (Cap included) 500 mL Bucket</p>	S500-4	Combi R515 Combi 508
 <p>TR250(500) 250 mL tube adaptor 500 mL bucket</p>	75.5 x 98.7	 <p>250 mL</p>			
 <p>TR100(500) 100 mL tube adaptor to 500 mL bucket</p>	99 x 58	 <p>100 mL</p>			
 <p>TR50-4 50 mL tube adaptor to 500 mL bucket</p>	62.3 x 87	 <p>50 mL</p>			
 <p>TR50c-3 50 mL conical tube adaptor to 500 mL bucket</p>	60.5 x 124.4	 <p>50 mL conical</p>			
 <p>TR15-9 15 mL tube adaptor to 500 mL bucket</p>	29.2 x 97	 <p>15 mL</p>			
 <p>TR15c-7 15 mL conical tube adaptor 500 mL bucket</p>	29 x 91	 <p>15 mL conical</p>			
 <p>TR10-9 10 mL tube adaptor to 500 mL bucket</p>	16 x 87	 <p>10 mL</p>			
 <p>TR5-9 5 mL tube adaptor to 500 mL bucket</p>	5 mL : 13.2 x 87 3 mL : 13.2 x 60	 <p>5 mL</p>			

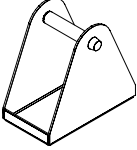
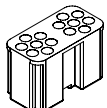
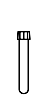
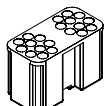
Adaptors of Swing-out Rotor

Adaptor	Bore Ø x L (mm)	Compatible Tubes and Capacity	Compatible Bucket	Compatible Rotor	Compatible Centrifuges
 TR50(85) 50 mL tube adaptor to 85 mL bucket	29 x 95	 50 mL			
 TR50c(85) 50 mL conical tube adaptor to 85 mL bucket	29.5 x 100	 50 mL conical		S85-4	Fleta 4
 TR15(85) 15 mL tube adaptor to 85 mL bucket	17 x 94	 15 mL	B85 85 mL Bucket		
 TR15c(85) 15 mL conical tube adaptor to 85 mL bucket	17 x 100	 15 mL conical			
 TR50c(50) 50 mL conical tube adaptor to 50 mL bucket	20 x 87	 50 mL conical			
 TR25(50) 25 mL tube adaptor to 50 mL bucket	20 x 87	 25 mL	B50 50 mL Bucket	S50-6	
 TR15(50) 15 mL tube adaptor to 50 mL bucket	18 x 87	 15 mL			
 HTR15-8 15(16) mL tube adaptor to HBTM	18 x 55	 8 x 15 mL			
 HTR10-12 10 mL tube adaptor to HBTM	13 x 55	 12 x 10 mL		HSR-4S	Fleta 5
 HTR5-14 5 mL tube adaptor to HBTM	11 x 55	 14 x 5 mL	HBTM Rack Holder		
 HTR3-20 Adaptor for 3 mL tube loads HBTM	10 x 55	 20 x 3 mL			

Accessories

Centrifuge Tubes

Micro Centrifuge Tube (1.5 mL)

- RCF rating : 25,000 xg
- Easy to handle cap
- Outstanding protection against unintentional opening during incubation and storage



ClickSeal Micro Centrifuge Tubes (1.7/2.0 mL)

- RCF rating : 27,000 xg
- Temperature range : -80°C ~ 121°C
- DNase, RNase and Pyrogen Free
- Flat lid and surface on the side for easy labeling
- Unique side molding prevents damage of lab gloves

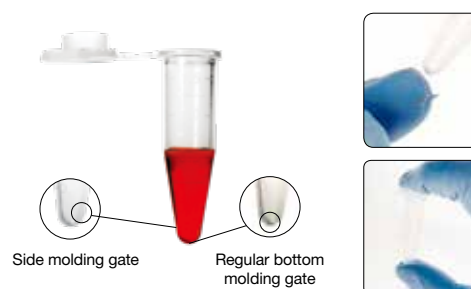

Ordering Information

Cat. No.	Description	Material	Max. RCF	Packing
LP-11500CP-00	Micro Centrifuge Tube, 1.5 mL	Polypropylene	25,000 xg	500 ea/10 pk
LP-11500CP-00-1				500 ea
NSCN1700-BP	ClickSeal Micro Centrifuge Tube 1.7 mL Nat Bags		27,000 xg	500 ea/10 pk
NSCN1700-BP-1				500 ea
NSCN2000-BP	ClickSeal Micro Centrifuge Tube 2.0 mL Nat Bags			400 ea/10 pk
NSCN2000-BP-1				400 ea

ARA Conical Centrifuge Tubes (15/50 mL)

- Non-pyrogenic / Non-cytotoxic / DNase, RNase-free / Human DNA-free
- Tight sealing screw cap
- External graduations with marking area
- Packed in zipper bags
- Cap : High-density Polyethylene
Body : Polypropylen



Ordering Information

Cat. No.	Description	Material	Max. RCF	D x H, mm	Packing
ARA-0050C	ARA Conical tube 50 mL	Cap : High-density Polyethylene Body : Polypropylen	14,000 xg	30 x 115	25 ea/bag, 500/box
ARA-0015C	ARA Conical tube 15 mL		13,000 xg	17 x 120	50 ea/bag, 500/box

Hanil Centrifuge Tubes (500 mL)

- RCF rating : 14,300 xg (TB4001) / 4,300 xg (TB4002)
- Polypropylene for excellent chemical resistance
- Autoclavable



Autofil Centrifuge Tubes

- High centrifugation stability
- Polypropylene for excellent chemical resistance and polycarbonate for repeatedly autoclavable
- Screw cap for easy access and sealing cap for leakproof assurance



Ordering Information

Cat. No.	Description	Material	Dimension (Ø x H, mm)	Max. RCF	Packing
HI_TB4001	Hanil 500 mL PP Tube (S-500) for Fixed Angle Rotor	Polypropylene	68.5 x 163	14,300 xg	1 ea
HI_TB4002	Hanil 500 mL PP Tube (U-500) for Swing Rotor		74 x 140	4,300 xg	1 ea
RS1801-RLS-1	Autofil™ Centrifuge Bottles (250 mL PP with Screw cap, nonsterile)	Polypropylene	59 x 129	8,250 xg	4 ea/pk
RS1802-RLS-1	Autofil™ Centrifuge Bottles (250 mL PC with Screw cap, nonsterile)	Polycarbonate		27,500 xg	
RS1803-RLS-1	Autofil™ Centrifuge Bottles (250 mL PP with Seal cap, nonsterile)	Polypropylene		31,700 xg	
RS1804-RLS-1	Autofil™ Centrifuge Bottles (250 mL PC with Seal cap, nonsterile)	Polycarbonate			
RS1805-RLS-1	Autofil™ Centrifuge Bottles (500 mL PP with Screw cap, nonsterile)	Polypropylene	68 x 168	8,250 xg	
RS1806-RLS-1	Autofil™ Centrifuge Bottles (500 mL PC with Screw cap, nonsterile)	Polycarbonate		13,500 xg	
RS1807-RLS-1	Autofil™ Centrifuge Bottles (500 mL PP with Seal cap, nonsterile)	Polypropylene		13,850 xg	
RS1808-RLS-1	Autofil™ Centrifuge Bottles (500 mL PC with Seal cap, nonsterile)	Polycarbonate			

Continuous Tubular Centrifuge

J1250

- Tubular type industrial centrifuge for continuous treatment
- Two phase (liquid/solid) separation
- High recovery of sludge (cake type)
- Water jacketed cooling system (optional)
- Up to two pumps
- Easy loading and unloading with safety 4 door-racks
- Intuitive touch-screen control panel
- Robust design and shock proof operation
- SUS (stainless steel use steel) type (Optional)



Harvesting Process



Mechanical Structure

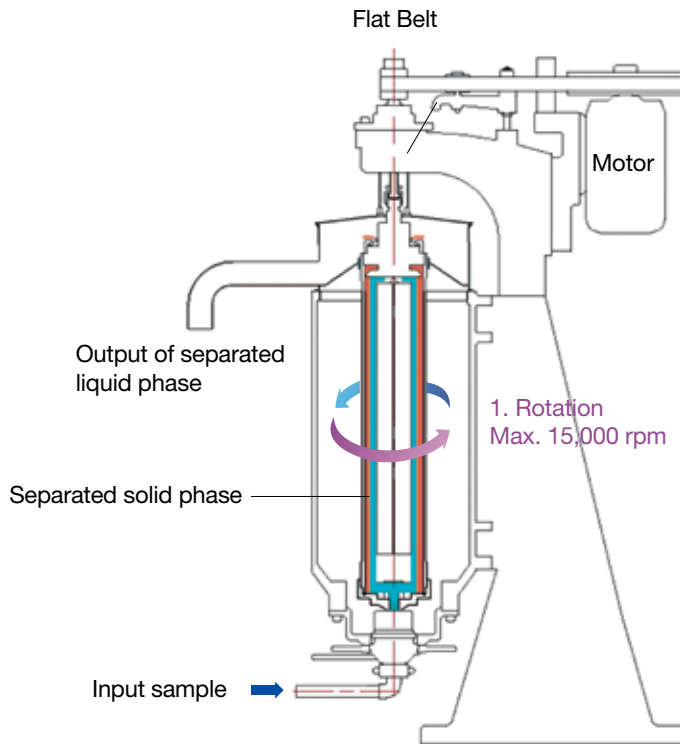

Bowl

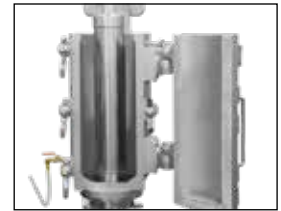

Door



Injection Pump

Peristaltic Injection Pump
or Diaphragm Pump



Controller

Applications

Pharmaceutical areas

Collection of pharmaceutical intermediates, herb extracts, plant fibers and chlorella

Food processing areas

Soy bean, fat, vegetable oil, starches, grains, gelatin, amino acids, soy sauce, reducing fat in milk

Chemistry industry areas

Cleaning and collection of ink, paints, ammonia, barium, aluminum, zinc, activated charcoal and stainings

Waste water treatment

Cleaning on straining waste water, leather waste water, petroleum tank sludge, waste oil

The other fields

Milk fat processing, cosmetics, cod-liver oil, yeast processing, and many other separation of solution and collection of solids

Technical Specifications

	Tubular Continuous Centrifuge, J1250
Speed	15,000 RPM / 15,800 xg
Max. Capacity	2,200 L/ hr when the density is 1 g/ml
Bowl Capacity	9 L
Bowl Dimension (inner)	125 (Ø) x 735 (L) mm
Bowl Material / Weight	SUS / 27 kg
Display & Control	10" Touch Screen LCD, Stand-alone
Parameters Displayed	Speed in RPM and RCF, Time, Program, Pump and Operational Status
Time Control	99 hr 59 min 59 sec or Continuous
Motor	3.7 kW, 50/60 Hz
Cooling Unit	Optional (Factory Installation)
Door Opening	Front
Case Material	Cast Iron (Optional SUS)
Power consumption	4.7 kW
Power Input	220V or 380V 3 Phase
Dimension of Main Body	840(W) x 450(D) x 1600(H) mm
Weight	Complete System : approx. 713 kg (Main body 564 kg, Bowl 27kg, Controller 52kg, Accessories incl. a Pump 70 kg)

Ordering Information

Cat. No.	Description
CC1102	J1250 Tubular Continuous Centrifuge, Main Body incl. A H-beam Base, In/Out Tubes and Operating Tools
CC2001	Bowl (SUS) with a Trolley and One Set of Harvesting Teflon Sheets (3 ea/set)
CC3001	Controller with 10" LCD and Inverter for 220V, Stand-alone
CC3002	Controller with 10" LCD and Inverter for 380V, Stand-alone
CC4001	Peristaltic Tube Pump incl. a Pump Stand (WT600-2J)
CC4002	Diaphragm Pump for Highly Viscous Sample (KD73L) incl. a Pump Stand
CC6001	Harvesting Sheet of Teflon (395 x 735 mm), 3 ea/set

Milk-fat Centrifuge

HA400

- Specialized centrifuge for milk-fat separation
- Diverse rotors and buckets for Gerber and Babcock type tubes
- Easy to use knob control for speed and time
- Transparent lid for easy monitoring
- Any customizations available

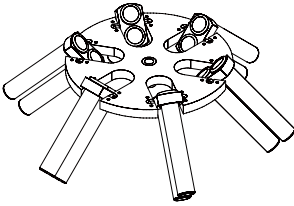
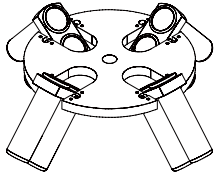
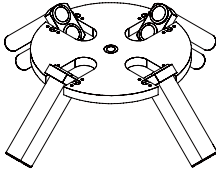

Swing-out Rotors for HA400

Rotor		Tube Capacity	Bore Ø x L (mm) Radius (mm)	Max. RPM (rpm) Max. RCF (xg)
SL100-6 (Gerber) 	SL100-4 (Gerber) 	100 mL Round	ø25 x 163 256.9	1,700 830
$\angle 90^\circ$ Max. RPM : 1,700 rpm Max. RCF : 830 xg Max. Capacity : SL100-6 (12 x 100 mL) SL100-4 (8 x 100 mL) Size (ø x H) : ø260 x 16 mm Max. height for tube fit : 215.5 mm				
SL100-4 (Babcock) 		100 ml Round	ø37 x 133.3 224.8	1,700 726
$\angle 90^\circ$ Max. RPM : 1,700 rpm Max. RCF : 726 xg Max. Capacity : 8 x 100 mL Size (ø x H) : ø260 x 16 mm Max. height for tube fit : 179 mm				

Technical Specifications

	HA400
Speed	1,700 rpm / 830 xg
Max. Capacity	Gerber : 12 (4, 6, 8) x 100 mL Bobcock : 8 (4) x 100 mL
Timer	0~30 minutes, Free
Power consumption	1 kW
Power consumption	220 V, 60 Hz
Dimension (Ø x L, mm)	670 x 420
Weight	33 kg
Cat. No.	HA-4

Sample Concentration

Centrifugal Vacuum Concentrators

HyperVAC-LITE / HyperVAC-MAX - p.62

Freeze Dryer & Cooling Trap

HyperCOOL 3055 / HyperCOOL 3110 / HyperCOOL 8080 - p.70

Gas Purging Evaporation Concentrator

HyperVAP HV300 - p.76

Centrifugal Vacuum Concentrators

HyperVAC-LITE / HyperVAC-MAX

Centrifugal Vacuum Concentrators

HyperVAC™-LITE

HyperVAC™-MAX



- Tabletop centrifugal concentrators with high space efficiency
- Equipped with a diaphragm pump (7 mbar) optimal for volatile chemical solvents
- Accommodates a wide range of sample containers: 0.5, 2.0, 15, 50 mL tubes and microplates
- Automatic control and digital reading of TIME, TEMP and VAC
- Efficient cold trapping by employing drip catcher kit with ice cold trap
- Effective concentration of nucleic acids or small volume of organic solvents

Applications

- Concentration for nucleic acids (DNA/RNA)
- Concentration for small and large volume of solvents



Technical Specifications of HyperVAC-LITE/MAX Centrifuges

		HyperVAC-LITE Centrifuge	HyperVAC-MAX Centrifuge
Max. RPM		2,000	
Max. capacity	Fixed angle	120 x 1.5/2.0 mL microtubes or 48 x 1.5/2.0 mL + 76 x 0.5 mL microtubes 32 x 10 mL	200 x 1.5/2.0 mL microtubes 24 x 30 mL
	Swing-out	2 loadings of MTP	4 loadings of MTP or DWP
Auto start / Stop of vacuum		Yes	
Chamber heating temperature Range		R.T ~ 80°C	
Vacuum pressure (mbar)		1 ~ 1,013	
Operating time		< 23 hr 59 min or continuous	
Power consumption (Centrifuge)		350 VA	700 VA
Power supply (V/Hz)		220v~230v, 50/60Hz (110v optional)	
Centrifuge dimension (W x D x H, mm)		375 x 445 x 252	475 x 560 x 350
Weight (kg)		22.5 (without Rotor)	37 (without Rotor)
Cat. No.		HVC-2124 (HVC-2124-110)	HVC-2200 (HVC-2200-110)
			



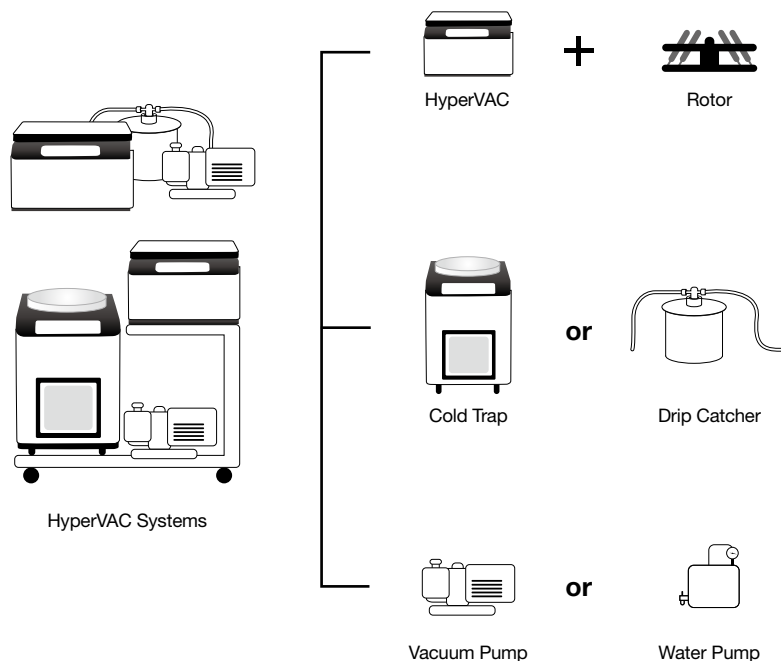





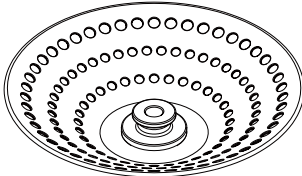

System Diagram

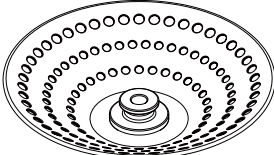

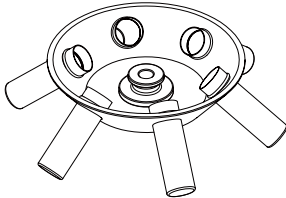



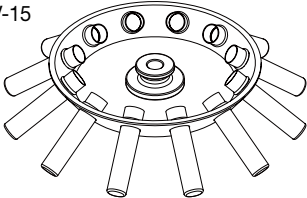

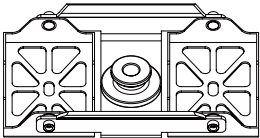
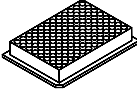

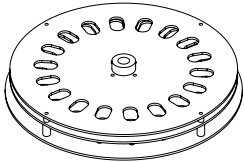

Centrifugal Vacuum Concentrators

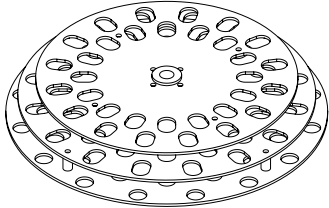
HyperVAC-LITE / HyperVAC-MAX

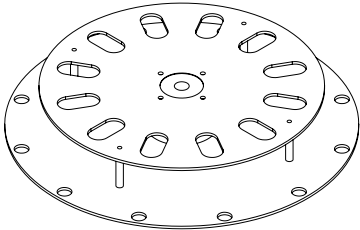
Rotors For HyperVAC-LITE (1)

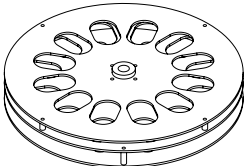
Rotor	Tube/Plate Type	Sleeve	Max. Tube Capacity	Hole Diameter (mm)
HRV-m0.5/2.0-124 	 1.5/2.0 mL 0.5 mL	-	48 x 1.5/2.0 mL + 76 x 0.5 mL	11.1 (1.5/2.0 mL) 8 (0.5 mL)
HRV-m2.0-120 	 1.5/2.0 mL	-	120 x 1.5/2.0 mL	11.1 mm
HRV-50-6 Incl. 6 ea x HLV-50 	 50 mL	HLV-50 	6 x 50 mL	30.4 x 101 mm
	 50 mL conical	HLV-50c 	6 x 50 mL conical	30.4 x 101 mm
HRV-15-12 Incl. 12 ea x HLV-15 	 15 mL	HLV-15 	12 x 15 mL	18 x 93 mm
HRV-mw-2 	 Microplate	-	2 loadings of microplate	130.3 x 88.5

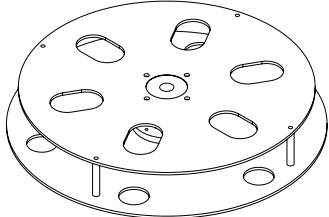





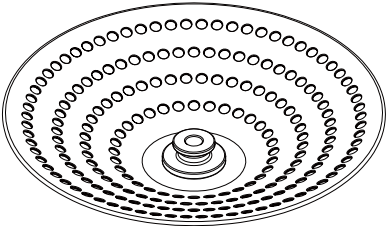

Rotors For HyperVAC-LITE (2)

Rotor	Tube/Plate Type	Max. Tube Capacity
HRV-10-18 	 10 mL	18 x 10 mL vial tube
HRV-10-32 	 10 mL	32 x 10 mL
HRV-15c-12 	 15 mL conical	12 x 15 mL conical
HRV-20-12 	 20 mL	12 x 20 mL vial tube
HRV-50c-6 	 50mL conical	6 x 50 mL conical

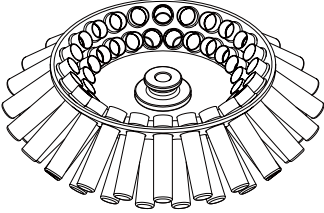

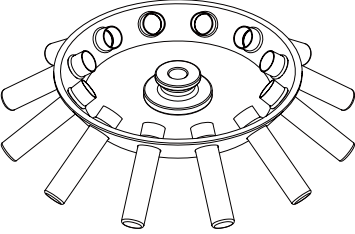



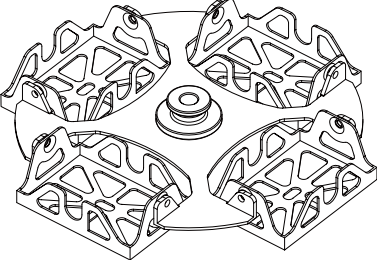
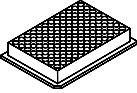

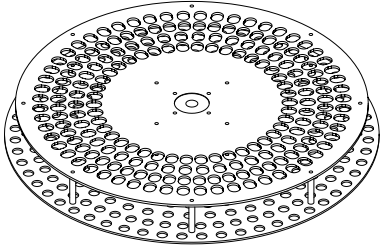

Centrifugal Vacuum Concentrators

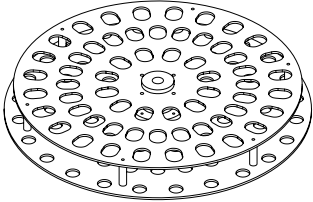
HyperVAC-LITE / HyperVAC-MAX

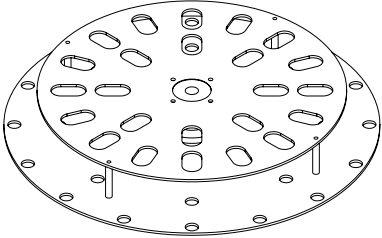
Rotors For HyperVAC-MAX (1)

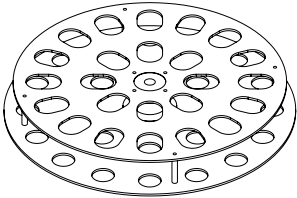
Rotor	Tube/Plate Type	Sleeve	Max. Tube Capacity	Hole Diameter (mm)
HRV-m2.0-200 	 1.5/2.0 mL 0.5 mL	-	48 x 1.5/2.0 mL + 76 x 0.5 mL	11.1 (1.5/2.0 mL) 8 (0.5 mL)
HRV-15-48 Incl. 48 ea x HLV-15 	 15 mL	HLV-15 	48 x 15 mL	18 x 93 mm
HRV-50-12 Incl. 12 ea x HLV-50 	 50 mL	HLV-50 	12 x 50 mL	30.4 x 101 mm
	 50 mL conical	HLV-50c 	12 x 50 mL conical	30.4 x 101 mm
HRV-mw-4 	 Microplate Deep-well plate	-	4 loadings of MTP or DWP	86.3 x 128.3

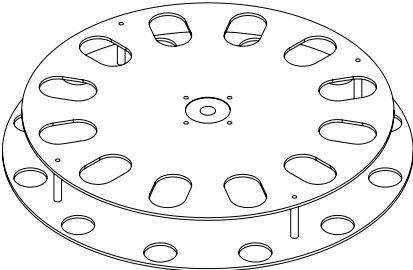
Rotors For HyperVAC-MAX (2)

Rotor	Tube/Plate Type	Max. Tube Capacity
<p>HRV-5-192</p> 	 <p>5 mL</p>	<p>192 x 5 mL</p>
<p>HRV-8-60</p> 	 <p>8 mL</p>	<p>60 x 8 mL vial tube</p>
<p>HRV-15c-24</p> 	 <p>15 mL conical</p>	<p>24 x 15 mL conical</p>
<p>HRV-30-24</p> 	 <p>30 mL</p>	<p>24 x 30 mL vial tube</p>
<p>HRV-50c-12</p> 	 <p>50mL conical</p>	<p>12 x 50 mL conical</p>











Centrifugal Vacuum Concentrators

HyperVAC-LITE / HyperVAC-MAX

HyperVAC Package Information

Cat. No.	Description	Vacuum Range
<p>HHVL-AWP</p> 	<p>HyperVAC-LITE System Incl. a Drip Cather Kit a and a Water Pump HVC-2124 + HRV-m0.5/2.0-124 + HV-DC20a + HVP-VE11</p>	<p>998 mbar</p>
<p>HHVL-BDP</p> 	<p>HyperVAC-LITE System Incl. a Drip Cather Kit b and a Diaphragm Pump HVC-2124 + HRV-m0.5/2.0-124 + HV-DC20b + HVP-MP001</p>	<p>7 mbar</p>
<p>HHVM-BDP</p> 	<p>HyperVAC-MAX System Incl. a Drip Cather Kit b and a Diaphragm Pump HVC-2200 + HRV-m2.0-200 + HV-DC20b + HVP-MP001</p>	<p>7 mbar</p>
<p>HHVM-HCA</p> 	<p>HyperVAC-MAX System Incl. a HyperCOOL -55°C/4L, a HC Trap Plate, a Vacuum Hose, Rotary Vane Pump, Oil Mist Trap, All Connections & a Table A HVC-2200 + HRV-m2.0-200 + HHC-3055 + HHC-CPP + two HHC-VH + HVP-W2V20 + HVP-WOF150 + HVCT-MA</p>	<p>0.0013 mbar</p>
<p>HHVM-HCB</p> 	<p>HyperVAC-MAX System Incl. a HyperCOOL -110°C/4L, a HC Trap Plate, a Vacuum Hose, Rotary Vane Pump, Oil Mist Trap, All Connections & a Table B HVC-2200 + HRV-m2.0-200 + HHC-3110 + HHC-CPP + two HHC-VH + HVP-W2V20 + HVP-WOF150 + HVCT-MB</p>	<p>0.0013 mbar</p>

Ordering Information

Cat. No.		Description
HyperVAC Concentrator Main System		
HVC-2124		HyperVAC-LITE Centrifuge, Teflon coated, with Heat and Time Control incl. an Fixed Angle Rotor, HRV-m0.5/2.0-124 (220V, 50/60 Hz)
HVC-2124-110		HyperVAC-LITE Centrifuge, Teflon coated, with Heat and Time Control incl. an Fixed Angle Rotor, HRV-m0.5/2.0-124 (110V, 50/60 Hz)
HVC-2200		HyperVAC-MAX Centrifuge, Teflon coated, with Heat and Time Control incl. an Fixed Angle Rotor, HRV-m2.0-200 (220V, 50/60 Hz)
HVC-2200-110		HyperVAC-MAX Centrifuge, Teflon coated, with Heat and Time Control incl. an Fixed Angle Rotor, HRV-m2.0-200 (110V, 50/60 Hz)
Pump		
HVP-VE11		Water Pump, 18 L/min X 2, 0.0998Mpa (998 mbar)
HVP-MP001		Chemistry Diaphragm Pump MZ 2C NT (ref. VB732300) (2.3 m ³ /n, 7 mbar)
HVP-W2V20		High Vacuum Rotary Vane Pump, 0.4 kW (0.5 HP), 200 L/min, 1 x 10 ⁻³ torr (12 m ³ /n, 0,0013 mbar)
HVP-WOF150		Oil Mist Trap
Drip Catcher		
HV-DC20a		Drip Catcher Kit a, Acrylic, ø20 cm, Height 16 cm incl. 500 mL Glass Bottle and Connections to Water Pump (a 50 cm Soft Hose /10 cm Vac Hose (ø12/25 mm) with 2 clamps to connect to HyperVAC centrifuge and a Y-Shape Soft Hose to Water Pump)
HV-DC20b		Drip Catcher Kit b, Acrylic, ø20 cm, Height 16 cm incl. 500 mL Glass Bottle and Connections to Diaphragm Pump (two 50 cm Soft Hose /10 cm Vac Hose (ø12/25 mm) with 2 clamps each to connect to HyperVAC centrifuge and Diaphragm Pump)
Cooling Trap		
HHC3055		HyperCOOL -55°C Cooling Trap, 4 L, Teflon Coated, w/ Digital Display and Time Control incl. a Vacuum Hose and Clamps (220V, 50/60 Hz)
HHC3055-110		HyperCOOL -55°C Cooling Trap, 4 L, Teflon Coated, w/ Digital Display and Time Control incl. a Vacuum Hose and Clamps (110V, 50/60 Hz)
HHC3110		HyperCOOL -110°C Cooling Trap, 4 L, Teflon Coated, w/ Digital Display and Time Control incl. a Vacuum Hose and Clamps (220V, 50/60 Hz)
HHC3110-110		HyperCOOL -110°C Cooling Trap, 4 L, Teflon Coated, w/ Digital Display and Time Control incl. a Vacuum Hose and Clamps (110V, 50/60 Hz)
Table		
HVCT-MA		Table A Type for HyperVAC-MAX with HyperCOOL Underneath and a Pump Back-sided
HVCT-MB		Table B Type for HyperVAC-MAX with a Pump Underneath

Freeze Dryer & Cooling Trap

HyperCOOL 3055 / HyperCOOL 3110 / HyperCOOL 8080

Freeze Dryers & Cooling Traps

HyperCOOL™

3055 / 3110 / 8080



- Effective for fast freeze drying of any samples
- HyperVAC-MAX empowered by HyperCOOL guarantees capacity and performance at higher level.
- HyperCOOL by itself, when equipped with manifolds or chambers, becomes a versatile freeze dryer.
- Extended applications for concentrating wider range or larger volume of solvents.
- The compatible vacuum rotary vane pump generates vacuum down inside the chamber.
- Up to 8 external bottles can be accommodated by the manifolds of HyperCOOL.
- Automatic De-Vac and De-Ice functions installed

Applications

- Study and QC of dried foods like dried fruits, meats, etc.
- Stock of bacteria, virus, fungi, etc.
- Seed preservation of plants or mushrooms
- Improved preservation of flowers and dry display study
- Pharmaceutical study and production
- Research and production of vaccine and antidote
- Tissue or cell preparation for EM analysis
- Medical research
- Archaeological finds like books, textiles, leather
- Restoration of wet documents



Technical Specifications of HyperCOOL Cooling Traps

	HC3055	HC3110	HC8080
Ultimate Chamber Temp (at RT) (°C)	-55	-110	-80
Chamber Volume (L)	4		8
Trap (Chamber) Size (Ø x L)	165 x 202		310 x 250
ICE Condensing Capacity (kg)	3		8
ICE Condensing Performance (kg/day)	2.5		-
Compressor	1/2 HP	1/3 HP x 2	1 HP x 2
Refrigerant	R507	R507/R1150	R23/R507
Digital Readout	Time, Temperature		Time, Program, Temperature, Vacuum Pressure
Function	KEYLOCK, DEFROST, VACUUM, TIME		COOLING, VACUUM
Power consumption (Resting, VA)	642	819	1500
Power supply(V/Hz)	220 V/50-60 Hz (110 V optional)		
Dimension (W x D x H, mm)	400 x 660 x 570		710 x 610 x 960
Weight (kg)	58	72	195
Cat. No.	HHC-3055 (HHC-3055-110) 	HHC-3110 (HHC-3110-110) 	HHC-8080 (HHC-8080-110) 



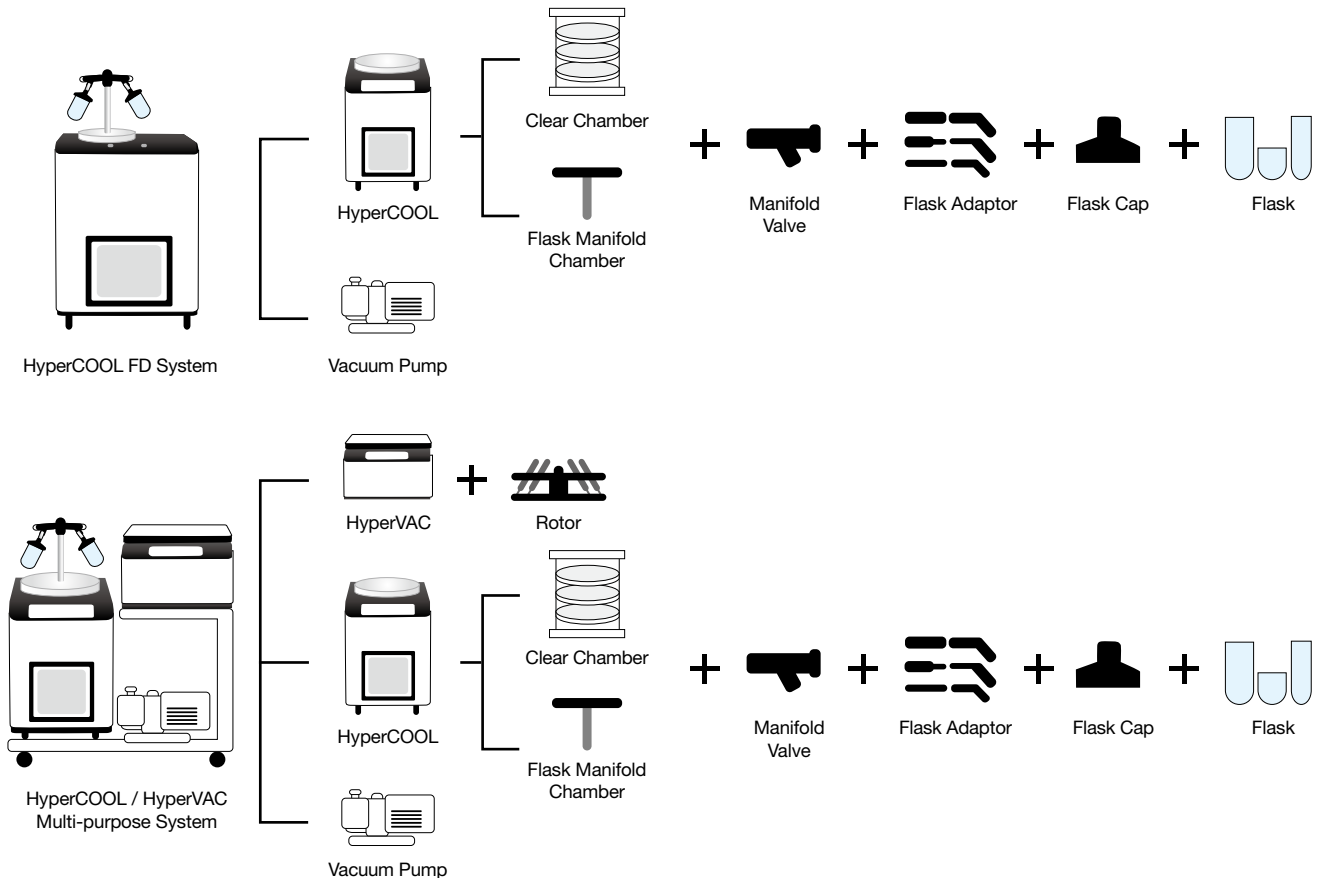



System Diagram of HyperCOOL Freeze Drying System









Freeze Dryer & Cooling Trap

HyperCOOL 3055 / HyperCOOL 3110 / HyperCOOL 8080

HyperCOOL Package Information (1)

Cat. No.		Description
<p>HHC3055-M4B HHC3110-M4B</p>		<p>Manifold Type Freeze Drying System -55°C / -110°C with 4 Valves Basic incl. a Rotary Vane Pump, Oil Mist Trap & Connections HHC-3055/HHC-3110 + HHC-CPB + HHC-MFB-4V + HHC-VH + HVP-W2V20 + HVP-WOF150</p>
<p>HHC3110-CHR</p>		<p>Chamber Type Freeze Drying System -110°C with 3 Shelves Rack incl. a Rotary Vane Pump, Oil Mist Trap & Connections HHC-3110 + HHC-CPB + HHC-CH30P + HHC-CR25 + HHC-VH + HVP-W2V20 + HVP-WOF150</p>
<p>HHC3110-CH4VR</p>		<p>Multi-Type Freeze Drying System -110°C with 3 Shelves Rack & 4 Valves Chamber incl. a Rotary Vane Pump, Oil Mist Trap & Connections HHC-3110 + HHC-CPB + HHC-CH30-4V + HHC-CR25 + HHC-VH + HVP-W2V20 + HVP-WOF150</p>
<p>HHC3110-CH8VR</p>		<p>Multi-Type Freeze Drying System -110°C with 3 Shelves Rack & 8 Valves Chamber incl. a Rotary Vane Pump, Oil Mist Trap & Connections HHC-3110 + HHC-CPB + HHC-CH30-8V + HHC-CR25 + HHC-VH + HVP-W2V20 + HVP-WOF150</p>
<p>HMHC3110-M4EC</p>		<p>Multi-Purpose, Vacuum Concentration and Freeze Drying System -110°C with 8 Valves Manifold incl. a Rotary Vane Pump, Oil Mist Trap, Connections & a Table B HVC-2200 + HVCT-MB + HHC-3110 + HHC-CPB + HHC-MFB-4V + HHC-MFE-4V + two HHC-VH + HVP-W2V20 + HVP-WOF150</p>
<p>HMHC3110-CH8VRC</p>		<p>Multi-Purpose, Vacuum Concentration and Freeze Drying System -110°C with 3 Shelves Rack & 8 Valves Chamber incl. a Rotary Vane Pump, Oil Mist Trap, Connections & a Table B HVC-2200 + HVCT-MB + HHC-3110 + HHC-CPB + HHC-CH30-8V + HHC-CR25 + two HHC-VH + HVP-W2V20 + HVP-WOF150</p>













HyperCOOL Package Information (2)

Cat. No.		Description
HHC8080-M4B		<p>Manifold Type Freeze Drying System -80°C with 4 Valves Basic incl. HHC8080 + HHC-CPB(8) + HHC-MFB-4V</p>
HHC8080-M6B		<p>Manifold Type Freeze Drying System -80°C with 6 Valves Basic incl. HHC8080 + HHC-CPB(8) + HHC-MFB-6V</p>
HHC8080-M8B		<p>Manifold Type Freeze Drying System -80°C with 8 Valves Basic incl. HHC8080 + HHC-CPM(8) + HHC-MFB-8V</p>
HHC8080-CHR		<p>Chamber Type Freeze Drying System -80°C with 3 Shelves Rack incl. HHC8080 + HHC-CPB(8) + HHC-CH30P + HHC-CR25</p>
HHC8080-CH4VR		<p>Multi-Type Freeze Drying System -80°C with 3 Shelves Rack & 4Valves Chamber incl. HHC8080 + HHC-CPB(8) + HHC-CH30-4V + HHC-CR25</p>
HHC8080-CH8VR		<p>Multi-Type Freeze Drying System -80°C with 3 Shelves Rack & 8 Valves Chamber incl. HHC8080 + HHC-CPB(8) + HHC-CH30-8V + HHC-CR25</p>





Freeze Dryer & Cooling Trap

HyperCOOL 3055 / HyperCOOL 3110 / HyperCOOL 8080

Ordering Information of HyperCOOL Accessories (1)

Cat. No.		Description
HyperCOOL Cover Plate		
HHC-CPP		HyperCOOL HC3055, HC3110 Trap Plate for Connection Vacuum Hose to Vacuum Concentrator
HHC-CPP-A		HyperCOOL HC3055, HC3110 Trap Plate for Connection Vacuum Hose to Vacuum Concentrator with Table A (GVCT-MA)
HHC-CPB		HyperCOOL HC3055, HC3110 Acrylic Base for Manifold or Chamber
HHC-CPM		HyperCOOL HC3055, HC3110 Acrylic Base for HC-MFB-8V
HHC-CPP(8)		HyperCOOL HC8080 Trap Plate for Connection Vacuum Hose to Vacuum Concentrator
HHC-CPB(8)		HyperCOOL HC8080 Acrylic Base for Manifold or Chamber
HHC-CPM(8)		HyperCOOL HC8080 Acrylic Base for HHC-MFB-8V
Manifold		
HHC-MFB-4V		4-Valve Manifold Basic with four rubber valves on a stainless steel bar, 30 cm
HHC-MFB-6V		6-Valve Manifold Basic with six rubber valves on a stainless steel bar, 30 cm
HHC-MFE-4V		4-Valve Manifold Extension with four rubber valves on a stainless steel bar, 20 cm
HHC-MFE-6V		6-Valve Manifold Extension with six rubber valves on a stainless steel bar, 20 cm
HHC-MFB-8V		8-Valve Manifold Basic with 8 rubber valves on a stainless steel bar, 30 cm

Ordering Information of HyperCOOL Accessories (2)

Cat. No.		Description
Chamber and Rack		
HHC-CH30P		Acrylic Chamber Trunk and Plain Top, ø30 cm, height 40 cm
HHC-CH30-4V		Acrylic Chamber Trunk and Top with 4 Rubber Valves, ø30 cm, height 40 cm
HHC-CR25		Stainless Steel Rack with 3 Sets of Shelves and Trays, ø25cm (Trays can be inserted up to 5)
HHC-CR-TS		A Set of a Tray and a Shelf
HHC-CH30-8V		Acrylic Chamber Trunk and Top with 8 Rubber Valves, ø30 cm, height 40 cm
Freeze Drying Glass Flask		
FD2009		Freeze Drying Glass Flask 40 mL (Ø45 mm)
FD2010		Freeze Drying Glass Flask 80 mL (Ø 45 mm)
FD2011		Freeze Drying Glass Flask 120 mL (Ø 45 mm)
FD2012		Freeze Drying Glass Flask 150 mL (Ø 45 mm)
FD2013		Freeze Drying Glass Flask 300 mL (Ø 45 mm)
FD2013-1		Freeze Drying Glass Flask 300 mL (Ø 70 mm)
FD2014		Freeze Drying Glass Flask 600 mL (Ø 70 mm)
FD2015		Freeze Drying Glass Flask 900 mL (Ø 70 mm)
FD2016		Freeze Drying Glass Flask 1,200 mL (Ø 70 mm)
FD2017		Freeze Drying Glass Flask 2,000 mL (Ø 70 mm)
Others		
FD2006		Stainless steel connector
FD2007		Rubber lid for 45 mm diameter Flask
FD2008		Rubber lid for 70 mm diameter Flask
FD1001		Vacuum Pump W2V20
FD1002		Oil Mist Trap
HHC-AA		Acetal Adaptor for the connection Vacuum Hose to Rubber Valve
HHC-VH		Vacuum Hose with 2 clamps, 100 cm



Gas Purging Evaporation Concentrator

HyperVAP HV300

Gas Purging Evaporation Concentrator

HyperVAP™

- Accelerated evaporation performance by gas purging mechanism
- Automated, programmable and reproducible
- Proprietary semi-helical gas flow mechanism to achieve the highest evaporation rate
- Diverse dimensions of nozzles and tube racks can be tailored upon customer needs.
- Four independent timer settings for different solvents
- Dual-step control of gas pressure and time to prevent “bumping” of the sample on startup
- Differentiated monitoring functions: 3-side transparent glass panels, blue backlight (on/off switchable) and traffic lights
- Optimized for evaporating organic solvents including sample preparations for chromatography
- Safety features: tempered glass panels, automatic gas shutoff function, traffic lights (fan, door, heater)



Maximized Evaporation by Semi-helical Air Flow (Patented)

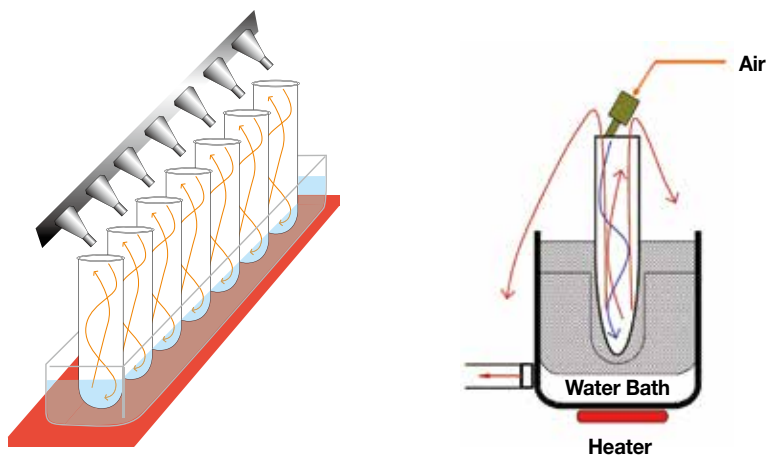

Reference Data

Solvent \ Pressure	40 psi	30 psi	20 psi
Hexane	1:50	2:10	3:20
Methanol	5:10	6:30	9:50
Acetonitrile	5:45	7:10	11:40
Ethanol	6:10	8:30	15:30

(min:sec)

Experimental Conditions

- Sample volume : 5 mL in 20 mL tube
- Temperature : 40°C
- Gas : nitrogen gas

Applications

- Pharmaceutical biotech compounds
- Clinical samples
- Environmental samples
- Forensic and crime samples
- Agrochemical samples
- Food and beverage analysis

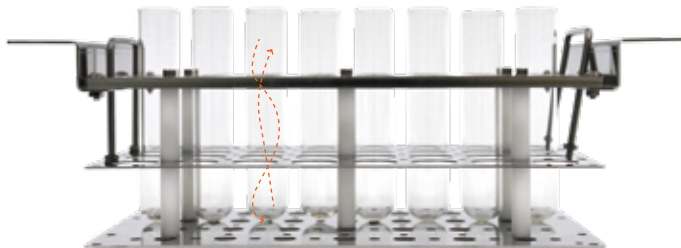

Gas Purging Evaporation Concentrator

HyperVAP HV300

Standard Nozzles & Racks

- 4 x 8 nozzle & a tube rack for 24 x 120 mm tubes
- 3 x 6 nozzle & a tube rack for 30 x 120 mm tubes
- 3 x 5 nozzle & a tube rack for 38 x 140 mm tubes
- 2 x 3 nozzle & a tube rack for 72 x 140 mm tubes
- Customized nozzle assembly and tube rack and optionally available

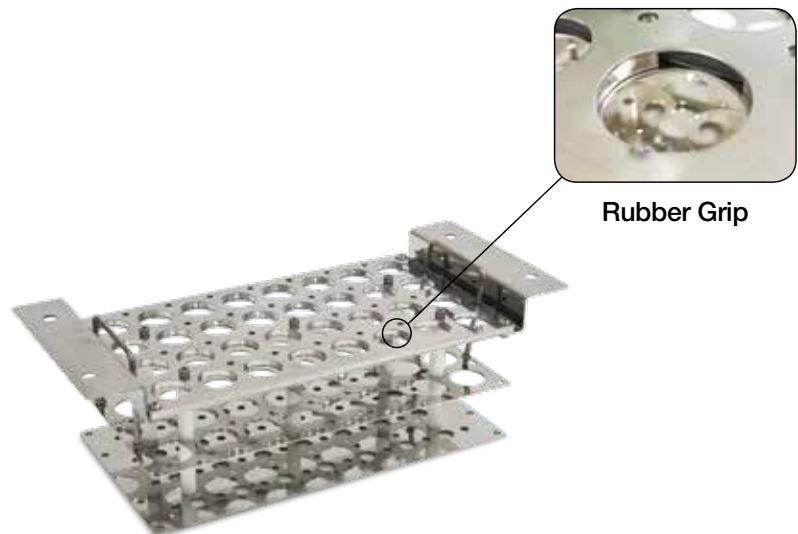

Technical Specifications

		HyperVAP
Sample Capacity	Number of Samples	6~32
	Sample Volume (mL)	5~300
Gas		Compressed air, N ₂ , etc.
Pressure	Operation Gas Pressure (psi)	15~50
	Pressure Control	Automated dual-step control (initial & operating pressure)
Max. Time for Initial Pressure (min)		~ 99
Max. Time Control (min)		~ 999 (4 independent channels)
Water Bath Temperature (°C)		~ 99
Forced Vapor Evacuation		Yes (by fan)
Power consumption		800 VA
Dimension (W x D x H, mm)		590 x 340 x 320
Weight (kg)		26.5

Ordering Information

Cat. No.	Description
HV-300 concentrator consists of a complete system installed with a nozzle assembly and a tube rack, incl. nozzle caps.	
HGP-300-48	HV300 with 4 x 8 nozzles assembly and a choice of a tube rack
HGP-300-36	HV300 with 3 x 6 nozzles assembly and a choice of a tube rack
HGP-300-35	HV300 with 3 x 5 nozzles assembly and a choice of a tube rack
HGP-300-23	HV300 with 2 x 3 nozzles assembly and a choice of a tube rack
Nozzle	
HGP-N48	Nozzle assembly, 4 x 8 (32 positions)
HGP-N36	Nozzle assembly, 3 x 6 (18 positions)
HGP-N35	Nozzle assembly, 3 x 5 (15 position)
HGP-N23	Nozzle assembly, 2 x 3 (6 position)
HGP-NC	Nozzle caps, 8/pk
Tube Rack	
HGP-R48-24	Tube rack for 24 mm x 120 mm (Ø x L) tubes (4 x 8 positions)
HGP-R48-16	Tube rack for 16 mm x 100 mm (Ø x L) tubes (4 x 8 positions)
HGP-R48-15	Tube rack for 15 mm x 70 mm (Ø x L) tubes (4 x 8 positions)
HGP-R36-30	Tube rack for 30 mm x 120 mm (Ø x L) tubes (3 x 6 positions)
HGP-R35-38	Tube rack for 38 mm x 140 mm (Ø x L) tubes (3 x 5 positions)
HGP-R23-72	Tube rack for 72 mm x 140 mm (Ø x L) tubes (2 x 3 positions)

Sample Growing

Laboratory Fermentors

LiFlus GX / GM - p.82

Photo Bioreactors

PBR - p.88

CO₂ Incubator

ARA P150 - p.90

Laboratory Fermentors

LiFlus GX / GM

Laboratory Fermentors

LiFlus GX

- Optimized for high density microbial growth
- Wide ranges of vessels of single, double or bowl types from 1.5 L to 14 L
- Individually controlled four peristaltic pumps for pH, DO, anti-foam and feeding
- Intuitive control with 7" touch screen display
- Accurate PID temperature control



Applications

- Microbial fermentation
- Cell cultivation
- Production of biomass
- Extracellular metabolites
- Intracellular components

Main Control Screen

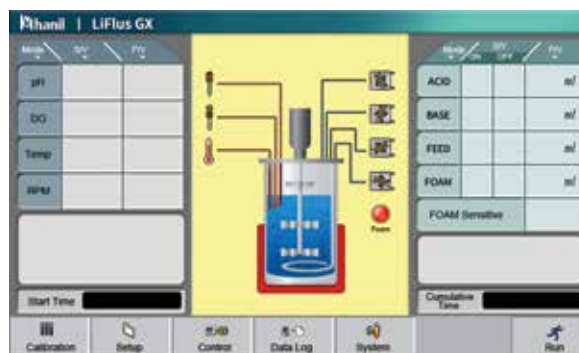

Structure of Laboratory Fermentor, LiFlus GX

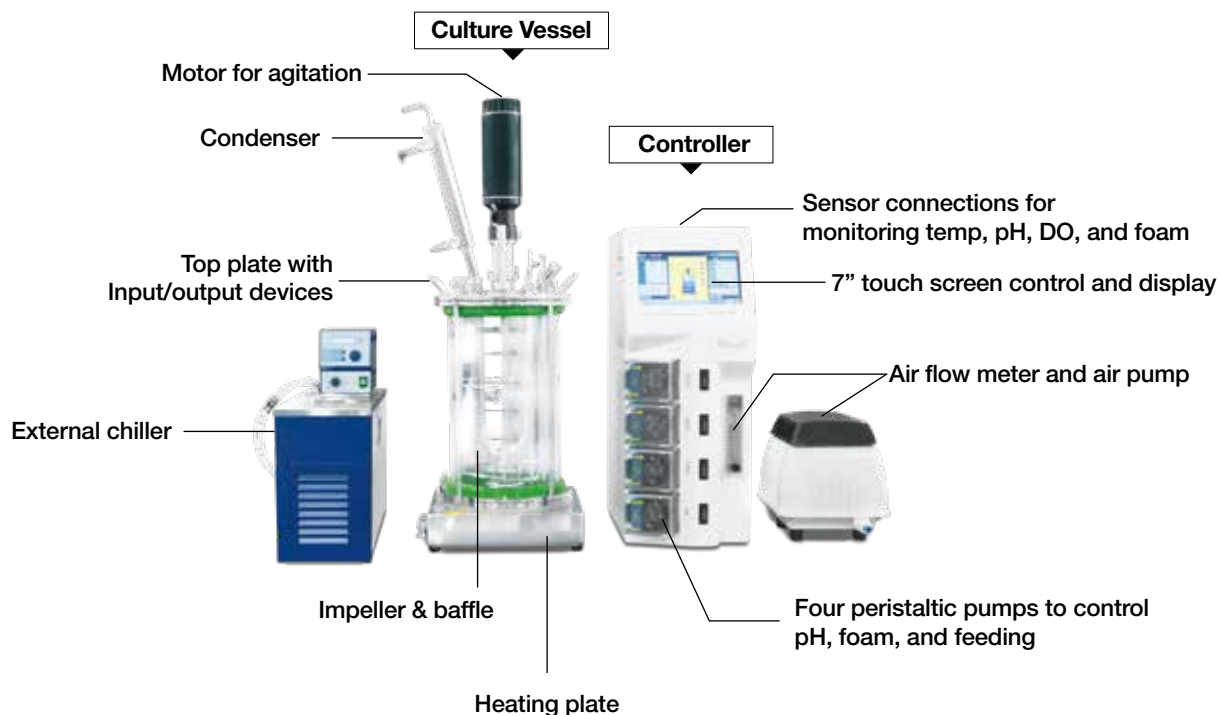

Availability of Vessel Types and Sizes

Vessel Type	1.5L	2L	3L	5L	7L	10L	14L
Single	●		●	●	●	●	
Single round		●	●	●	●		
Double			●	●	●	●	●
Bowl type						●	●



Single



Single Round



Double



Bowl

Laboratory Fermentors

LiFlus GX / GM

Basic Diagram of Culture Vessel and Variations

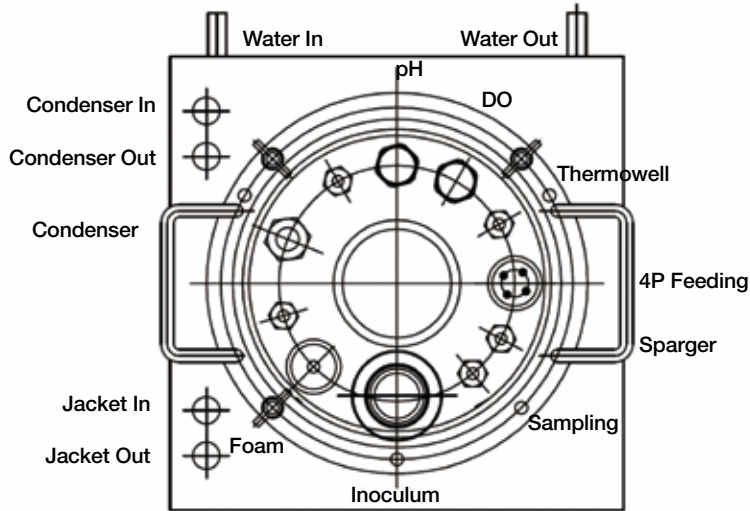

- Ports on the top plate can be composed by the necessities of controls and inputs /outputs.

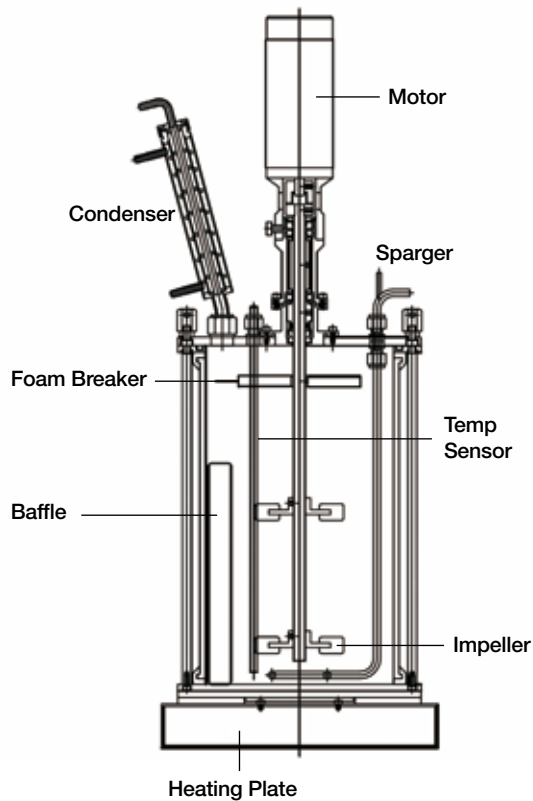

- A motor power and condenser size need to be selected by the vessel size.
- Sparger type and the size of foam breaker should be selected by growing sample's requirements.
- Heating method can be selected between direct heating plate, heating blanket, or double vessel.

Technical Specifications

		LiFlus GX	LiFlus GM
Type		Single system	Multi system
Controller	Control & Display	7" wide touch screen	
	Feeding Pumps	Up to 4 peristaltic pumps per one controller	
	Dimension (W x D x H, mm)	190 x 350 x 480 mm	
	Net Weight	12 kg	
	Power consumption	500 W	
Vessels	Type	Single flat bottom, Single round, Double, Bowl types	
	Capacity	1.5L, 3L, 5L, 7L, 10L or 14L	
Agitation	Range	100 ~ 1,200 rpm	
	Motor	DC motor, 60 or 150W	
	Impeller Type	Rushton, Pitched-paddle, Marine-blade, or Varied type	
Temperature Control	Control range	8 ~ 70°C	
	Thermostat system	8 ~ 70°C (±0.1°C) / Pt-100 probe heating & cooling PID control / built-in heat exchanger / automatic cooling water valve	
	Heating	Heating plate or blanket pad	
	Cooling	By internal cold finger and/or external chiller	
Aeration		By air sparger and air pump with air flow meter	
pH Range		pH 2.0~12.0	
DO Range		0 ~200%, DO cascade to agitation	
Anti-foam Sensing		Conductivity type	

- Impeller type should be chosen by the characteristics of growing sample from Rushton turbine, pitched blade, or marine-blade, or varied impeller.



Rushton
Turbine Impeller



Pitched
Paddle Impeller



Marine Impeller



Varied Impeller

Laboratory Fermentors

LiFlus GX / GM

Ordering Information (1)

Cat. No.	Description
Controller and Accessories	
FE1002	LiFlus GX controller, without pumps and air flow meter
FE3081	Peristaltic pump (upto 4 pumps can be installed on one controller), 14 rpm
FE3051	Air flow meter (rotameter), 200~2,500 cc/min for 1.5L (w.v.1L)
FE3052	Air flow meter (rotameter), 200~2,500 cc/min for 3L (w.v.2.1L)
FE3053	Air flow meter (rotameter), 0.5~ 5L/min for 5L (w.v.3L)
FE3054	Air flow meter (rotameter), 1~ 10L/min for 7L (w.v.5L) or 10L (w.v.7L)
FE3055	Air flow meter (rotameter), 1~25L/min for 14L (w.v.10L)
FE2106	Air compressor (air flow 20 L/min, pressure 0.1kgf/cm ² , input 18 W for 1.5~14L)
Single Vessel, borosilicate glass vessel with top SUS plate pH, DO, antifoam, thermo, inoculation, sampling, and 4 feeding ports, silicone connecting tubes and cold finger (over 3L)	
FE1102	Single vessel 1.5L, vessel (I.D 115 mm, V.H 135 mm, 1:1.2), top plate (180 D/mm, SUS)
FE1103	Single vessel 3L, vessel (I.D 133 mm, V.H 220 mm, 1:1.7), top plate (220 D/mm, SUS)
FE1104	Single vessel 5L, vessel (I.D 170 mm, V.H 220 mm, 1:1.3), top plate (220 D/mm, SUS)
FE1105	Single vessel 7L, vessel (I.D 170 mm, V.H 310 mm, 1:1.8), top plate (220 D/mm, SUS)
FE1106	Single vessel 10L, vessel (I.D 190 mm, V.H 355 mm, 1:1.8), top plate (220 D/mm, SUS)
FE1107	Single vessel 14L, vessel (I.D 190 mm, V.H 355 mm, 1:1.8), top plate (220 D/mm, SUS)
Single Round Vessel, borosilicate glass vessel with SUS vessel supporter and top plate pH, DO, antifoam, thermo, inoculation, sampling, and 4 feeding ports, silicone connecting tubes and cold finger (over 3L)	
FE1131	Single round vessel 2L, vessel (I.D 115 mm, V.H 135 mm, 1:1.2), top plate (180 D/mm, SUS)
FE1132	Single round vessel 3L, vessel (I.D 133 mm, V.H 220 mm, 1:1.7), top plate (220 D/mm, SUS)
FE1133	Single round vessel 5L, vessel (I.D 170 mm, V.H 220 mm, 1:1.3), top plate (220 D/mm, SUS)
FE1134	Single round vessel 7L, vessel (I.D 170 mm, V.H 310 mm, 1:1.8), top plate (220 D/mm, SUS)
Double Vessel, borosilicate glass double vessel with SUS vessel supporter and top plate pH, DO, antifoam, thermo, inoculation, sampling, and 4 feeding ports, silicone connecting tubes and cold finger (over 3L)	
FE1112	Double vessel 3L, vessel (I.D 130 mm, V.H 220 mm, 1:1.7), top plate (220 D/mm, SUS)
FE1113	Double vessel 5L, vessel (I.D 145 mm, V.H 300 mm, 1:1.2), top plate (220 D/mm, SUS)
FE1114	Double vessel 7L, vessel (I.D 160 mm, V.H 330 mm, 1:1.7), top plate (220 D/mm, SUS)
FE1115	Double vessel 10L, vessel (I.D 230 mm, V.H 350 mm, 1:1.7), top plate (220 D/mm, SUS)
FE1116	Double vessel 14L, vessel (I.D 270 mm, V.H 375 mm, 1:1.7), top plate (220 D/mm, SUS)
Bowl Type Vessel, borosilicate glass double vessel with bowl type SUS base and top SUS plate pH, DO, antifoam, thermo, inoculation, sampling, and 4 feeding ports, silicone connecting tubes and cold finger (over 3L)	
FE1121	Bowl vessel 10L, vessel (I.D 190mm, V.H 355mm, 1:1.8), top plate (220 D/mm, SUS)
FE1122	Bowl vessel 14L, vessel (I.D 190mm, V.H 500mm, 1:2.6), top plate (220 D/mm, SUS)
Heating and Cooling Apparatus	
FE1151	Heating plate with water in/out port for single vessel, 1.5L (210 x 210 x 40 mm)
FE1152	Heating plate with water in/out port for single vessel, 3L (220 x 220 x 40 mm)
FE1153	Heating plate with water in/out port for single vessel, 5L, 7L (250 x 250 x 40 mm)
FE1154	Heating plate with water in/out port for single vessel, 10L (280 x 280 x 40 mm)
FE1161	Heating blanket for single round vessel, 2L
FE1162	Heating blanket for single and single round vessels, 5L
FE1163	Heating blanket for single and single round vessels, 7L
FE1164	Heating blanket for single vessel, 10L
FE2001	6L chiller for single vessel, 3L, 5L
FE2002	8L chiller for single vessel, 7L
FE2003	12L chiller for single vessel, 10L

Ordering Information (2)

Cat. No.	Description
Motor for Agitation	
FE1201	DC motor for 1.5~7L vessel (60 W, DC 24V 3A, 100~850 rpm)
FE1202	DC motor for 10~14L vessel (150 W, DC 24V 8A, 100~850 rpm)
Impeller for Agitation, SUS	
FE1402	Rushton turbine impeller (O.D. 60 mm) for double 5L vessel
FE1403	Rushton turbine impeller (O.D. 80 mm) for single 5L, 7L, double 7L vessels
FE1407	Rushton turbine impeller (O.D. 100 mm) for single 10L, bowl 10L, 14L vessels
FE1411	Pitched-paddle impeller (O.D. 65 mm) for single 1.5L, 3L, double 3L vessels
FE1412	Pitched-paddle impeller (O.D. 80 mm) for single 5L, 7L, double 5L vessels
FE1413	Pitched-paddle impeller (O.D. 100 mm) for 10L, 14L vessels
FE1421	Marine-blade impeller (O.D. 65 mm) for single 1.5L, 3L, double 3L vessels
FE1422	Marine-blade impeller (O.D. 80 mm) for double 5L Vessels
FE1423	Marine-blade impeller (O.D. 100 mm) for single 5L, 7L, double 7L, bowl 10L, 14L vessels
FE1431	Varied impeller (O.D. 65 mm) for single 1.5L, 3L, double 3L vessels
FE1432	Varied impeller (O.D. 80 mm) for single 5L, 7L, double 5L vessels
FE1433	Varied impeller (O.D. 100 mm) for 10L, 14L vessels
Foam Breaker, SUS	
FE1501	Foam breaker (O.D. 75 mm) for single 1.5L, 3L, double 3L vessels
FE1502	Foam breaker (O.D. 90 mm) for single 5L, 7L, double 5L vessels
FE1503	Foam breaker (O.D. 110 mm) for 10L, 14L vessels
Sparger, SUS	
FE4011	Ring type sparger, removable
FE4012	Linear type sparger, removable
FE4013	Micro sparger with 20 µm holes
Condenser, SUS	
FE1701	Standard condenser
FE1703	Big size condenser for 10L, 14L vessels
Sensors	
FE153X	pH electrode, length 120, 225, 325, or 425 mm
FE154X	Cable for pH Electrode, 1 m or 3 m
FE157X	DO (dissolved oxygen) electrode, length 120, 220, 320, or 420 mm
FE158X	Cable for DO electrode, 1 m or 3 m
FE163X	Temperature sensor, Length 160, 220, 260, 320, 360, 510 mm
FE1601	Anti foam electrode, L100 DIA7 PORT 12 for 1.5L Vessel
FE1602	Anti foam electrode, L150 DIA7 PORT 12 for 3, 5, 7, 10, 14L Vessels
FE161X	Cable for anti foam electrode, length 1 m or 1.5 m
Reagent Bottle, Pyrex, 0.2 µm PTFE Filter (Ø 25mm) included	
FE1801	250 mL reagent bottle, 4 ea/set
FE1802	500 mL reagent bottle, 4 ea/set
FE1803	1,000 mL reagent bottle, 4 ea/set

Photo Bioreactors

PBR - Lab Scale / Pilot Scale

Photo Bioreactors

PBR

Lab Scale / Pilot Scale

- Photosynthetic microorganism cultivation
- Various types of photo bioreactor (flat, α -type, pipe and etc.)
- LED illumination with full spectrum imitates natural sunlight by emitting light at 430 nm, 630 nm, white LED
- Easy to scale up
- No standard models
- Easy and costly customization according to individual application



Vessel Type Photo Bioreactor,
Illuminated with Inner LED Bars



Pilot Scale, Plate Type Photo Bioreactor,
Illuminated by Internal LED Plate

Applications

- Phototrophic microorganism cultivation
- Production of phototrophic microalgae biomass

Technical Specifications

		PBR Lab Scale
Agitation	Drive	Top drive motor (mechanical drive)
	Range	100~1,200 rpm
	Impeller	2-Rushton turbine impeller
Temperature	Range & Sensor	Ambient + 3~80°C RTP (Pt-100), PID control
Aeration	Sparger & Gas mode	Ring sparger (round type), Air-flow meter (standard) or 2 gas and 4 gas mixer (option)
Exhaust system	Filter & Condenser	0.2µm air filter cartridge, SUS 316
pH	Range	2.0~12.0 pH of set point, PID control
	Electrode	Gel type
DO	Range	0~200%, PID control
	Electrode	Polarographic type
Anti-foam	Electrode	Conductivity type
Peristaltic Pumps	Control	4 constant speed pumps each assignable to a wide variety of function for control of acid, base, foam and feed
Recording	pH, DO, Temp, Foam, Agitation, Peristaltic pump, etc.	

		PBR Pilot Scale
Total volume illuminated	20~100 L	
Sterilization autoclave	Possible	
Photosynthetic module	Plate	
Illumination unit	White LED	
Illumination	On / Off control	
Air flow rate	5~20 L/min	
pH-control	CO ₂ Gas	
Temperature	Measurement & control	
Optical density	Turbidity sensor	



Vessel Type Photo Bioreactor,
Illuminated by External Octagon LED Panels



Pilot Scale, Plate Type Photo Bioreactor,
Illuminated by External LED Plates

CO₂ Incubator

ARA P150

CO₂ Incubator

ARA P150 / P170

- Direct heating CO₂ incubator
- Internal max. capacity 150 L/170 L
- Maximized inner space by no fan structure
- No fan, no vibration, no maintenance of HEPA filter, no spread-out of contamination
- Easy to clean interior and water pan
- Dual Beam NDIR Carbon Dioxide Sensor
- Intuitive 7" control touch screen and informative display
- USB port for data tracking



Applications

- Mammalian cell and tissue cultivation



USB port for data transfer

CO₂ Incubator

ARA P150

Technical Specifications

	P150	P170
Inner capacity	150 L	170 L
Door left/right	Factory Installed	On site
Fan	No	No
Decontamination	-	120°C Dry
External dimension (mm)	657W x 741D x 877H	720W x 639D x 908H
Internal dimension (mm)	470W x 520D x 610H	547W x 479D x 647H
Net weight	62 kg	91 kg

Display
7" LCD touch screen

Date Tracking
240 hours continuous

Temperature
- Microprocessor PID
Control system
- Range : Amb. +5 ~ 50°C
- Accuracy : ±0.2°C
- Uniformity : ±0.3°C
- Recovery time
: less than 10 min

rH system
- Humidity method
: Water pan
- Humidity range, %RH
: over 90%

CO₂ control
- Microprocessor PID
Control system
- Sensor : NDIR
- Control range : 0 ~ 20%
- Control accuracy : ±0.1
- Recovery rate : less than 7 min



Touchscreen with graphic display



3 shelves divided door

Ordering Information

Cat. No.	Product
APL150	ARA P150 CO ₂ Incubator with Single Glass Door, Left-Open
APR150	ARA P150 CO ₂ Incubator with Single Glass Door, Right-Open
APL170	ARA P170 Incubator with Single Glass Door, Left-Open
APR170	ARA P170 Incubator with Single Glass Door, Right-Open
APA-SPS	Shelf with 2 Supports, perforated, SS
APA-CGS	CO ₂ gas pressure regulator



Sample Storage

Deep Freezer Overview - p.96

Deep Freezers

Upright Type, ARA M/MD Series - p.98

Chest Type, ARA MC/MCD Series - p.102

Classic Chest Type, ARA MCC Series - p.104

Accessories - p.106

How to Select the Right Deep Freezer

Main Body

Q1. Space Availability?

Upright Type

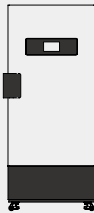

Q2-1. Capacity?

876L, 732L, 514L, 404L, 317L, 85L

Q2-2. Necessity of failure free compressor?

Dual Compressor (D)
Single Compressor

Q2-3. Easiness of door handling?

Automatic Door
Manual Door

Model Name

ARA MD500
ARA M500

Chest Type (C)



Q2-1. Capacity?

600L, 500L, 350L

Q2-2. Necessity of failure free compressor?

Dual Compressor (D)
Single Compressor

ARA MCD500
ARA MC500

Q2-1. Capacity?

438L, 375L, 314L, 237L, 136L

ARA MCC430

Accessories

Q3-1. Sample type & size ;
micro-tube, bottles, or tissues

Storage boxes
Rack dimensions

Q3-2. Easiness of In & Out

Open rack
Tray drawer
Box drawer

Q3-3. Auxiliary & Back-up system

LCO₂ back-up
LN₂ back-up
Chart recorder
External alarm

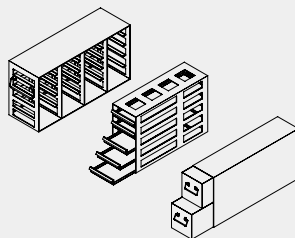

ARA M Deep freezers advanced functionality with intuitive display and control panel

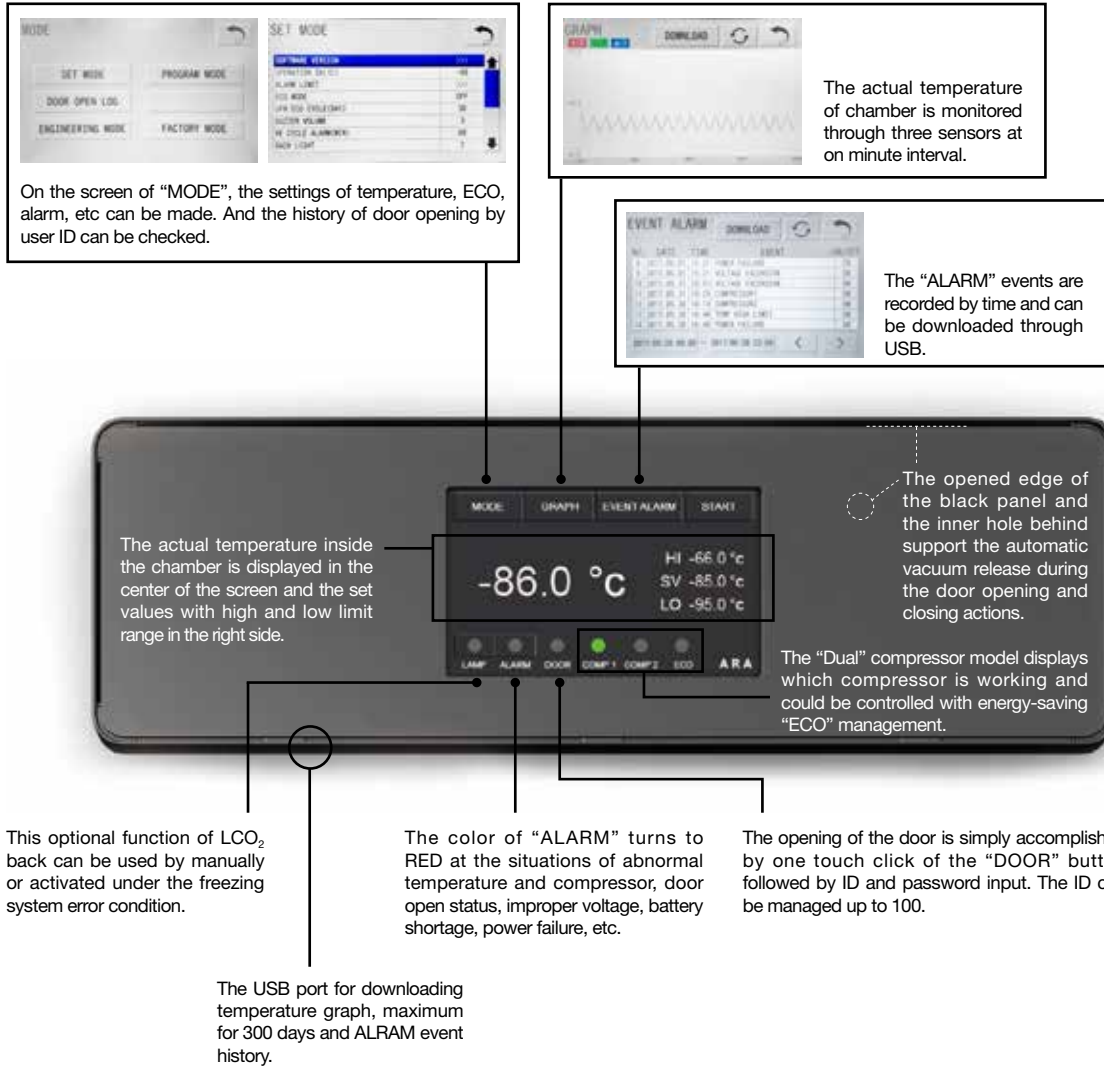

ARA M Deep Freezers scheme shortens the pull-down time of ultra-low temperature.

Model	ARA MD300	ARA MD500	ARA MD700
Time to -80 °C	120 min	180 min	210 min
Time to -90 °C	180 min	280 min	380 min
Time to -95 °C	220 min	330 min	-

Deep Freezers

Upright Type - ARA M/MD Series

Upright Type Deep Freezers

ARA M/MD Series

- Fast pull-down and recovery to optimal storage temperature (500L Dual / -95°C, 700L Dual / -90°C)
- Unique pin-less Block Condenser and Independent Compressor (single or dual selectable) structures
- Failure free Dual Brain PCB and dual Independent Compressor systems
- Effortless Auto-Door with safe lock& unlock function (optional manual door is available)
- Controllable ECO mode of dual compressor model for energy saving operation
- Informative 7" display and touch screen control
- Data tracking and storage to chart recorder or through USB transfer
- Alarm warning of text message transfer to max. 5 users
- No need of dust cleaning by very simple compressor and condenser structure
- LCO₂ or LN₂ backup system is available

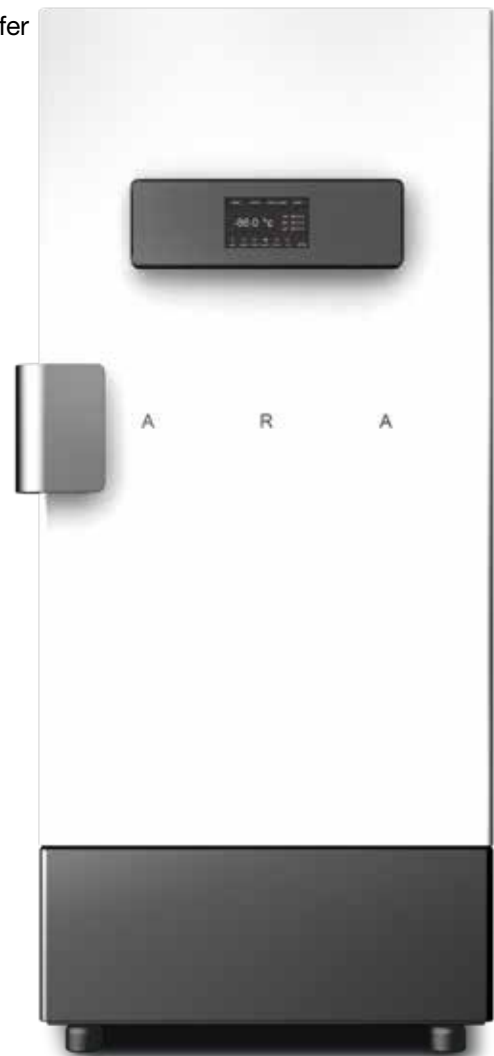

Robust and Flexible Design of Door Handle

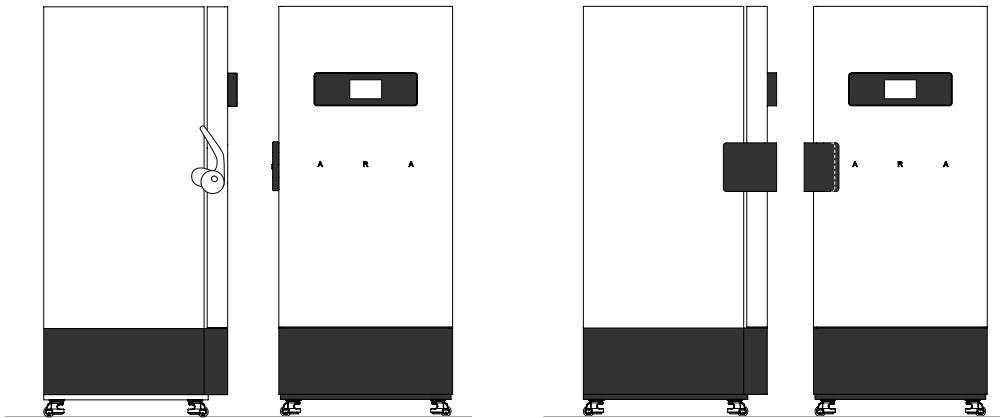

Manual Door

Automatic Door

Independent Dual Compressor System

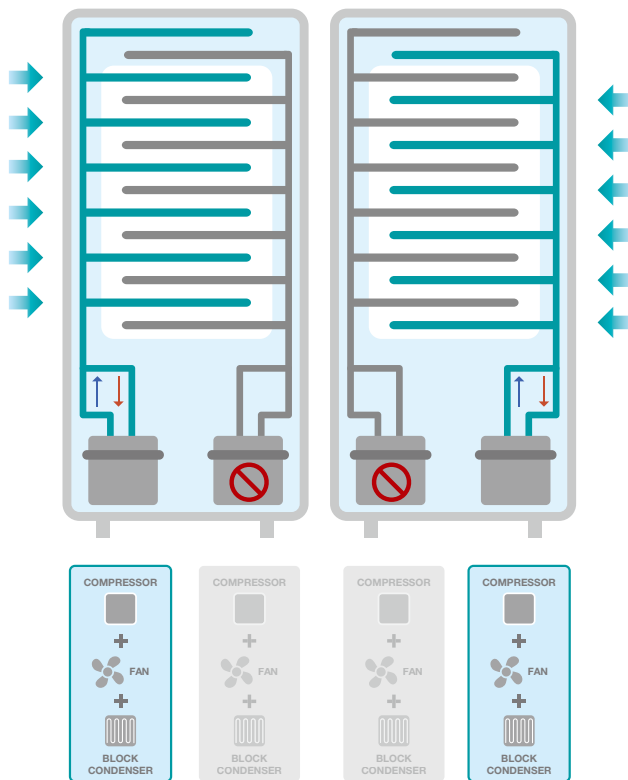

SMART Freezing System with Block Condenser

Deep Freezers

Upright Type - ARA M/MD Series

Technical Specifications

	Upright Type Deep Freezer
Capacity	85, 317, 404, 514, 732, 876 Lit.
Temperature range	-86°C / -80°C ~ -65°C or -95°C / 90°C ~ -65°C
Compressor	Hermetic Type, Single or Independent Dual Compressor (Eco mode of Dual type for economic operation)
Condenser Type	Block Condenser, No pin, Filter Free Mechanism
Refrigerant	Natural (CFC Free Refrigerant System)
Controller & Display	Failure free Dual Controller and 7" Touch Screen TFT LCD
Door	Door opening and closing by pressing a touch button on control screen (Manual Door is Optional)
Material	Internal Stainless Steel / External Powder Coated Steel Plate
Power supply	Single Phase, AC 230V, 50/60Hz (Optional AC 120V, 60Hz)



Ordering Information

		ARA M80	ARA M300	ARA MD300	ARA M400	ARA MD400	ARA M500	ARA MD500
Capacity		85 Lit.	317 Lit.		404 Lit.		514 Lit.	
Temperature Range		-86°C ~ -65°C	-86°C ~ -65°C	-95°C ~ -65°C	-86°C ~ -65°C	-95°C ~ -65°C	-86°C ~ -65°C	-95°C ~ -65°C
Compressor		Single	Single	Dual, Independent	Single	Dual, Independent	Single	Dual, Independent
Rack Capacity		2 x 2 tray for freezer box	3 x 4 tray for freezer box		4 x 4 tray for freezer box			
Chamber Dimension (W x D x H, mm)	Internal	340 x 485 x 520	470 x 515 x 1,310		600 x 515 x 1,310		600 x 655 x 1,310	
	External	572 x 830 x 1,147	800 x 892 x 1,990		930 x 892 x 1,990		930 x 1,032 x 1,990	
Net Weight		102 kg	190 kg	220 kg	220 kg	260 kg	245 kg	284 kg
Power consumption	Dual Mode	321 W/h	364 W/h	364 W/h	386 W/h	386 W/h	469 W/h	469 W/h
	Eco Mode			415 W/h		461 W/h		526 W/h
Cat. No.	Auto Door	-	AMUS300	AMUD300	AMUS400	AMUD400	AMUS500	AMUD500
	Manual Door	AMUS080-M	AMUS300-M	AMUD300-M	AMUS400-M	AMUD400-M	AMUS500-M	AMUD500-M

		ARA M700	ARA MD700	ARA M870	ARA MD870
Capacity		732 Lit.		876 Lit.	
Temperature Range		-80°C ~ -65°C	-90°C ~ -65°C	-80°C ~ -65°C	-90°C ~ -65°C
Compressor		Single	Dual, Independent	Single	Dual, Independent
Rack Capacity		6 x 4 tray for freezer box			
Chamber Dimension (W x D x H, mm)	Internal	880 x 635 x 1,310		880 x 760 x 1,310	
	External	1,210 x 1,012 x 1,990		1,210 x 1,137 x 1,990	
Net Weight		285 kg	327 kg	335 kg	385 kg
Power consumption	Dual Mode	508 W/h	508 W/h	547 W/h	547 W/h
	Eco Mode		576 W/h		613 W/h
Cat. No.	Auto Door	AMUS700	AMUD700	AMUS870	AMUD870
	Manual Door	AMUS700-M	AMUD700-M	AMUS870-M	AMUD870-M



Deep Freezers

Chest Type - ARA MC/MCD Series

Chest Type Deep Freezers

ARA MC/MCD Series

- Much safer and energy-saving deep freezer for not losing cooled status by door opening
- All features are the same with upright type deep freezer except the automatic door
- Installed with easy to move and heavy duty casters (4~6 casters)



Technical Specifications

	Chest Type Deep Freezer
Capacity	350, 500 or 600 Lit.
Temperature range	-86°C ~ -65°C or -95°C ~ -65°C
Compressor	Hermetic Type, Single or Independent Dual Compressor (Eco mode of Dual type for economic operation)
Condenser Type	Block Condenser, No pin, Filter Free Mechanism
Refrigerant	Natural (CFC Free Refrigerant System)
Controller & Display	Failure free Dual Controller and 7" Touch Screen TFT LCD
Door	Manual type
Material	Internal Stainless Steel / External Powder Coated Steel Plate
Power supply	Single Phase, AC 230V, 50/60Hz (Optional AC 120V, 60Hz)

Ordering Information

		ARA MC350	ARA MCD350	ARA MC500	ARA MCD500	ARA MC600	ARA MCD600
Capacity		350 Lit.		500 Lit.		600 Lit.	
Temperature Range		-86°C ~ -65°C	-95°C ~ -65°C	-86°C ~ -65°C	-95°C ~ -65°C	-86°C ~ -65°C	-95°C ~ -65°C
Compressor		Single	Dual, Independent	Single	Dual, Independent	Single	Dual, Independent
Rack Capacity		7 x 3 tray for freezer box		10 x 3 tray for freezer box		12 x 3 tray for freezer box	
Chamber Dimension (W x D x H, mm)	Internal	1,050 x 470 x 670		1,500 x 470 x 670		1,800 x 470 x 670	
	External	1,690 x 776 x 1,150		2,140 x 776 x 1,150		2,440 x 776 x 1,150	
Net Weight		190 kg	230 kg	220 kg	270 kg	250 kg	310 kg
Power consumption	Dual Mode	364 W/h	364 W/h	386 W/h	386 W/h	469 W/h	469 W/h
	Eco Mode		415 W/h		461 W/h		526 W/h
Cat. No.		AMCS350	AMCD350	AMCS500	AMCD500	AMCS600	AMCD600

Deep Freezers

Classic Chest Type - ARA MCC Series

Classic Chest Type Deep Freezers

ARA MCC Series

- Much safer and energy-saving deep freezer for not losing cooled status by door opening
- Simple display of temperature monitoring
- Minimalized efficient inner structure with aluminum plate
- No casters equipped for economic installation



Technical Specifications

	Classic Chest Type Deep Freezer
Capacity	136, 237, 314, 375, or 438 Lit.
Temperature range	-86°C ~ -65°C
Compressor	Hermetic Type , Single Compressor
Condenser Type	Block Condenser, No pin, Filter Free Mechanism
Refrigerant	Natural (CFC Free Refrigerant System)
Controller & Display	Digital Feedback Controller
Material	Internal Aluminum Plate / External Steel plate with Acrylic Acid Resin Coating
Power supply	Single Phase, AC 230V, 50/60Hz (Optional AC 120V, 60Hz)

Ordering Information

		ARA MCC130	ARA MCC230	ARA MCC310	ARA MCC370	ARA MCC430
Capacity		136 Lit.	237 Lit.	314 Lit.	375 Lit.	438 Lit.
Temperature Range		-86°C ~ -65°C				
Compressor		Single				
Rack Capacity		6 pcs of 11 (1 x 11) & 3 pcs of 7 (1 x 7) -placed Rack	12 pcs of 11 (1 x 11) & 3 pcs of 7 (1 x 7) -placed Rack	18 pcs of 11 (1 x 11) & 3 pcs of 7 (1 x 7) -placed Rack	21 pcs of 11 (1 x 11) & 3 pcs of 7 (1 x 7) -placed Rack	27 pcs of 11 (1 x 11) & 3 pcs of 7 (1 x 7) -placed Rack
Chamber Dimension (W x D x H, mm)	Internal	520 x 450 x 680	850 x 450 x 680	1,100 x 450 x 680	1,300 x 450 x 680	1,500 x 450 x 680
	External	720 x 730 x 860	1,050 x 730 x 860	1,300 x 730 x 860	1,500 x 730 x 860	1,700 x 730 x 860
Net Weight		45 kg	55 kg	67 kg	73 kg	82 kg
Power consumption		300W	400W	450W	500W	550W
Cat. No.		AMCS130	AMCS230	AMCS310	AMCS370	AMCS430

Accessories

Rack System for Freezer

Stainless Steel Rack for Upright Type Freezer

Rack Type	Small Size Rack			Medium Size Rack			Large Size Rack			X-Large Size Rack		
	Open Rack	Tray Drawer	Box Drawer	Open Rack	Tray Drawer	Box Drawer	Open Rack	Tray Drawer	Box Drawer	Open Rack	Tray Drawer	Box Drawer
Dimension (W x D x H, mm)	140 x 430 x 220		140 x 410 x 220	140 x 430 x 290		140 x 425 x 290	140 x 570 x 290			140 x 710 x 290		
Applicable Freezer	ARA M80			ARA M(D)300/400			ARA M(D)500/700			ARA M(D)870		
Quantity of Available Boxes	12 ea (3 x 4)			15 ea (3 x 5)		12 ea (3 x 4)	20 ea (4 x 5)		16 ea (4 x 4)	25 ea (5 x 5)		
Material	Stainless Steel											
Cat. No.	AMA-ORS	AMA-TDS	AMA-BDS	AMA-ORM	AMA-TDM	AMA-BDM	AMA-ORL	AMA-TDL	AMA-BDL	AMA-ORX	AMA-TDX	AMA-BDX

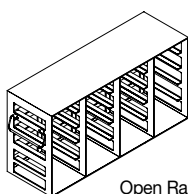

Open Rack

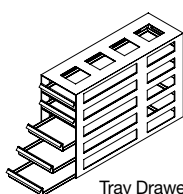

Tray Drawer

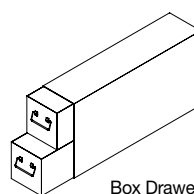

Box Drawer

Stainless Steel Rack for Chest Type Freezer

Rack Type	Open Rack	
Dimension (W x D x H, mm)	140 x 140 x 385	140 x 140 x 655
Applicable Freezer	ARA MC(D)350 / MC(D)500 / MC(D)600 ARA MCC130 / ARA MCC230 / ARA MCC310 / ARA MCC370 / ARA MCC430	
Quantity of Available Boxes	7 ea (1 x 7)	11 ea (1 x 11)
Material	Stainless Steel	
Cat. No.	AMA-SAS	AMA-SAM

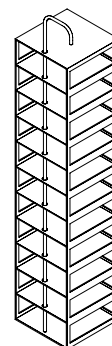

Open Rack for (Classic) Chest Type

Freezer Box

Cat. No.	Description
AMA-B001	Freezer box, Paper with dividers for 9 x 9 holes, 127 (W) x 127 (D) x 52 (H) mm
AMA-B002	Freezer box, PP with dividers for 9 x 9 holes, 127 (W) x 127 (D) x 52 (H) mm

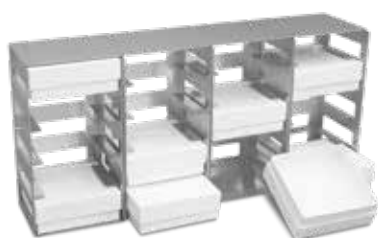

Optional Common Accessories

Temperature Chart Recorder

- Continuously monitor and record freezer temperature
- Easy to check the operation of the equipment
- 1 chart records 7days (included 60 charts)
- Recorder records temperatures from -100°C to 0°C
- Min/Max Temperature can be checked on digital display



Remote Alarm System

- Remote warnings for overtemperature (above -65°C)
- Alarm system is connected to the regulator and activates when the temperature rises
- Alarm is sent via phone or text
- Multiple phone numbers can be registered to receive alarm at the same time



LCO₂ Backup System (LCO₂ Gas Tank is optional)

- Protect samples of the freezer in case of power failure
- Liquid Carbon Dioxide (freezing point is -78°C) is injected into the chamber to keep the internal temperature below -65°C
- The operating time depends on the gas tank capacity.



Ordering Information

Cat. No.	Description
AMA-TR622	Temperature Chart Recorder
AMA-CP657	Chart Paper, 60 Charts per one box for 420 days recording in AMA-TR622
AMA-P222	Chart Recorder Replacement Pens, 6ea Red color, for AMA-TR622
AMA-RAS	Remote Wire/Wireless Alarm System
AMA-LCO	LCO ₂ Backup System

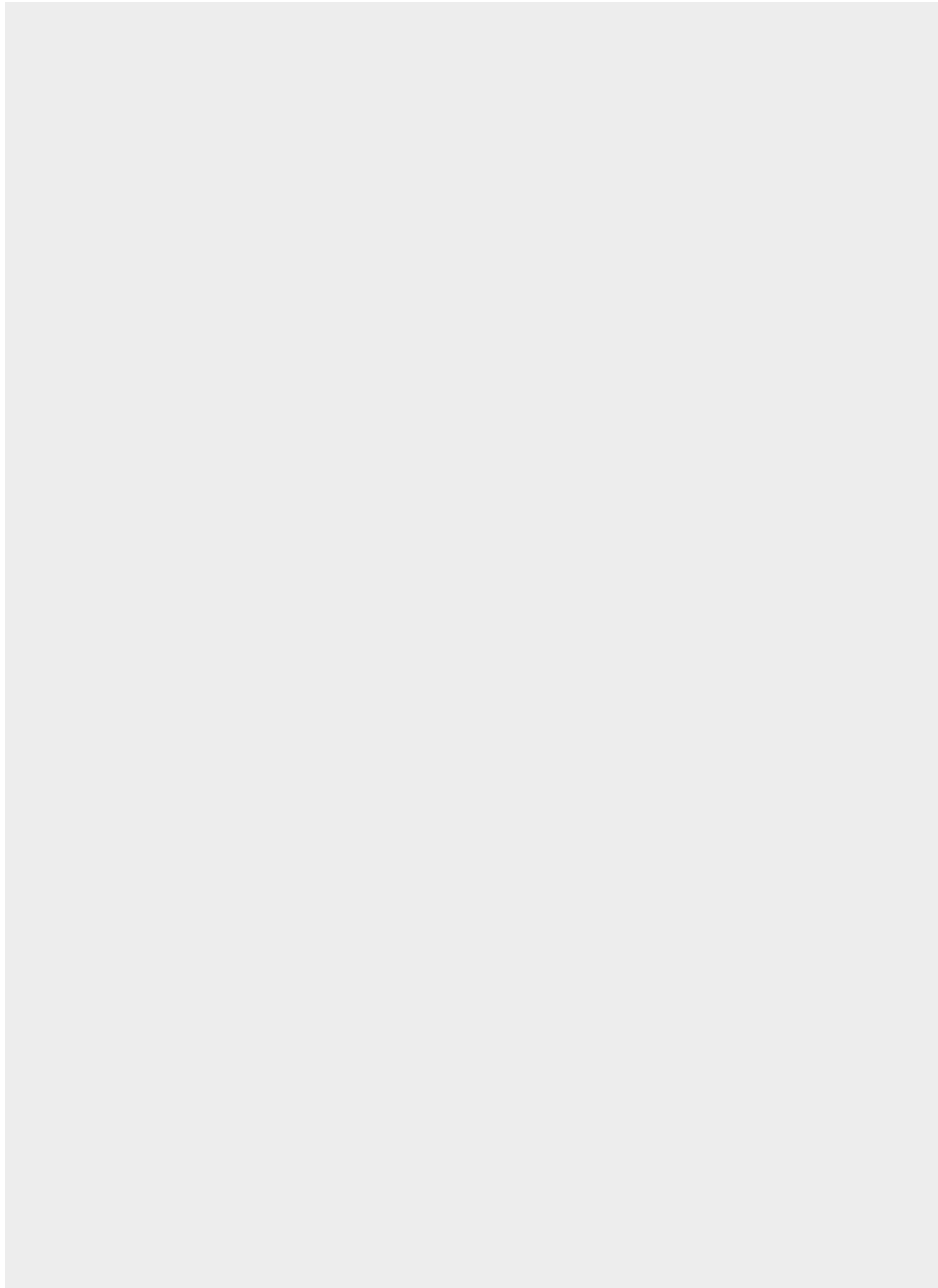

Distribution



Hanil Scientific Inc.

16 Arayukro, Gimpo 10136, Rep. of KOREA

T. 02-3452-8965 | T. +82-2-3472-0727 (Int'l)

info@ihanol.com | techsupport@ihanol.com

www.ihanol.com